

Spannzange / Collet ER16 DIN6499  
 Spannbereich / Clamping range: 1,0 - 10,0

Gewindebohrzange / Tapping Collet  
 ET-1-16 M1-M6

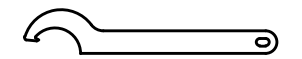
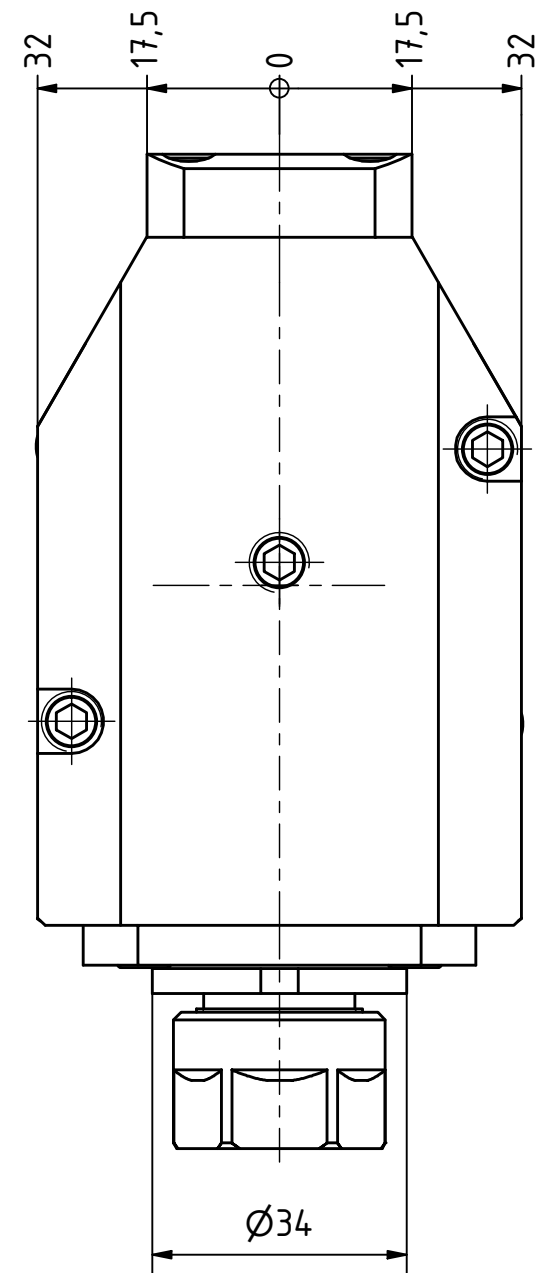
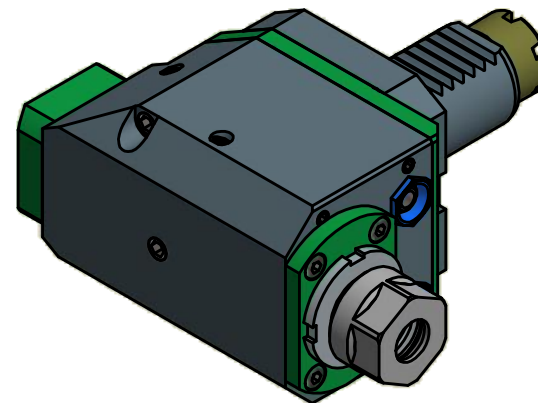

Hakenschlüssel  
 mit Nase  
 Hook wrench with  
 nose end  
 DIN1810 A 34x36

Copyright **EWS Tool Technologies**  
 Weitergabe und Vervielfaeltigung dieser Unterlage,  
 Verwertung und Mitteilung ihres Inhalts nicht  
 gestattet, soweit nicht ausdrecklich zugestanden.  
 Zuwiderhandlungen verpflichten zu Schadenersatz.

Bemerkung - Note

Technische Daten - technical data

Weight = 3.012 [kg]  
 Torque max. (M1/M2) = 15 / 5 [Nm]  
 Speed max. (n1/n2) = 6000 / 18000 [1/min]  
 Gear ratio (i)=n1:n2 = 1:3

Benennung - Title

Radial Bohr und Fräskopf  
 Radial drilling and milling head



Nr. - No.  
 60.3016TOEMR13

Technische Aenderungen vorbehalten!  
 Subject to technical modifications!

IDENT: D-EWS-127865

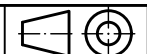

REV: -/B

MNR.

124846

QR