

Spannzange / collet ER25 DIN6499  
 Spannungsbereich / clamping range: 1,0 - 16,0  
 Gewindebohrzange / tapping collet  
 ET-1-25 M3-M10

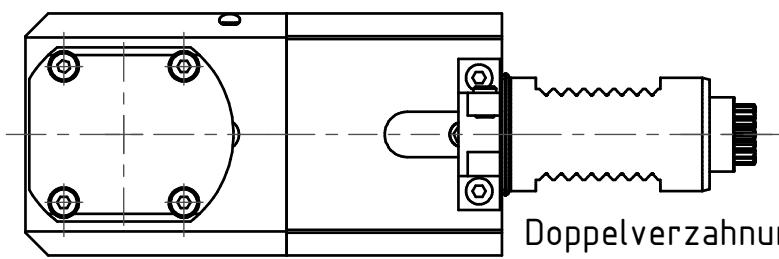
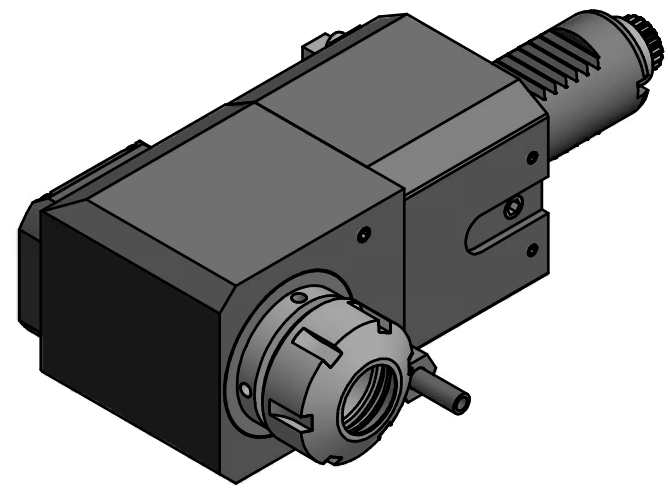
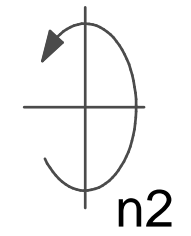

Doppelverzahnung Lizenz Traub  
 double tooth system licence Traub

Hakenschlüssel  
 mit Zapfen  
 Hook wrench  
 with fixed pin  
 DIN1810 B 40x42

Spannzangenschlüssel  
 Clamping wrench  
 225

Copyright **EWS Tool Technologies**  
 Weitergabe und Vervielfältigung dieser Unterlage,  
 Verwertung und Mitteilung ihres Inhalts nicht  
 gestattet, soweit nicht ausdrücklich zugestanden.  
 Zuwiderhandlungen verpflichten zu Schadenersatz.

Bemerkung - Note

Technische Daten - technical data

Weight	= 3.951 [kg]
Torque max. (M1/M2)	= 25 / 25 [Nm]
Speed max. (n1/n2)	= 8000 / 8000 [1/min]
Gear ratio (i)=n1:n2	= 1:1

Benennung - Title

**Radial Bohr und Fräskopf**  
*Radial drilling and milling head*

**EWS**  
 Tool Technologies

EWS Weigle GmbH & Co. KG  
 Maybachstr. 1  
 D-73066 Uhingen  
 www.ews-tools.de

Nr. - No.  
**60.3025LCTXRLFE**

Technische Änderungen vorbehalten!  
 Subject to technical modifications!

IDENT: D-EWS-212555

MNR.  
**156579**

