

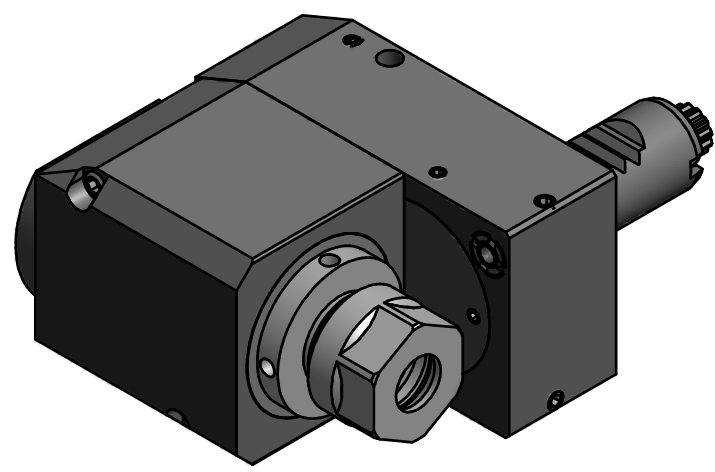



Spannzange / Collet ER16 DIN6499  
 Spannungsbereich / Clamping range: 1,0 - 10,0

Gewindebohrzange / Tapping Collet  
 ET-1-16 M1-M6



  
 Hakenschlüssel  
 mit Zapfen  
 Hook wrench  
 with fixed pin  
 DIN1810 B 34x36

Copyright **EWS Tool Technologies**  
 Weitergabe und Vervielfältigung dieser Unterlage,  
 Verwertung und Mitteilung ihres Inhalts nicht  
 gestattet, soweit nicht ausdrücklich zugestanden.  
 Zuwiderhandlungen verpflichten zu Schadenersatz.

Bemerkung - Note	Technische Daten - technical data Weight = 1.967 [kg] Torque max. (M1/M2) = 10 / 10 [Nm] Speed max. (n1/n2) = 8000 / 8000 [1/min] Gear ratio (i)=n1:n2 = 1:1	Benennung - Title <b>Radial Bohr und Fräskopf. zurückges</b> <b>Radial drill. and mill. head offset</b>	 EWS Weigele GmbH & Co. KG Maybachstr. 1 D-73066 Uhingen www.ews-tools.de Nr. - No. <b>80.2016CTXR</b>	Technische Aenderungen vorbehalten! Subject to technical modifications! IDENT: D-EWS-196355 MNR. <b>156523</b>	 REV: -/- 
------------------	--	---	--	--	--