

Spannzange / collet ER25 DIN6499
Spannbereich / clamping range: 1,0 - 16,0

Gewindebohrzange / tapping collet
ET-1-25 M3-M12

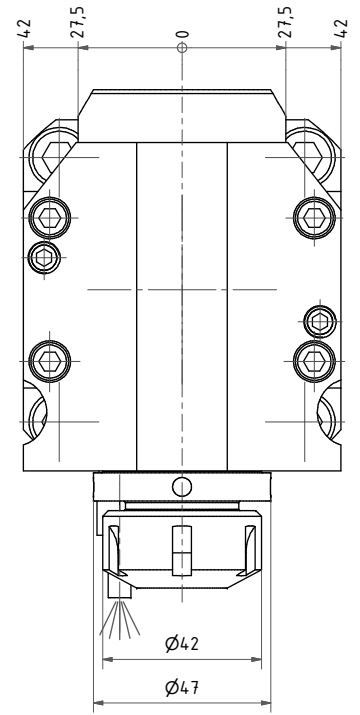

Z (2 : 1)

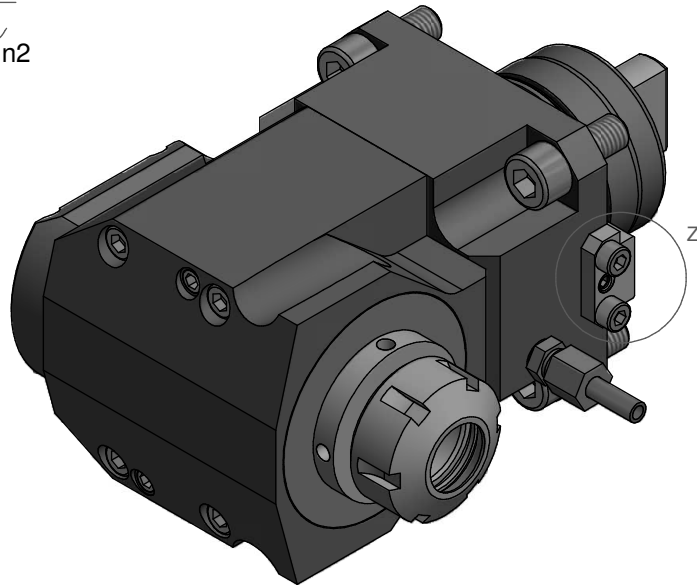
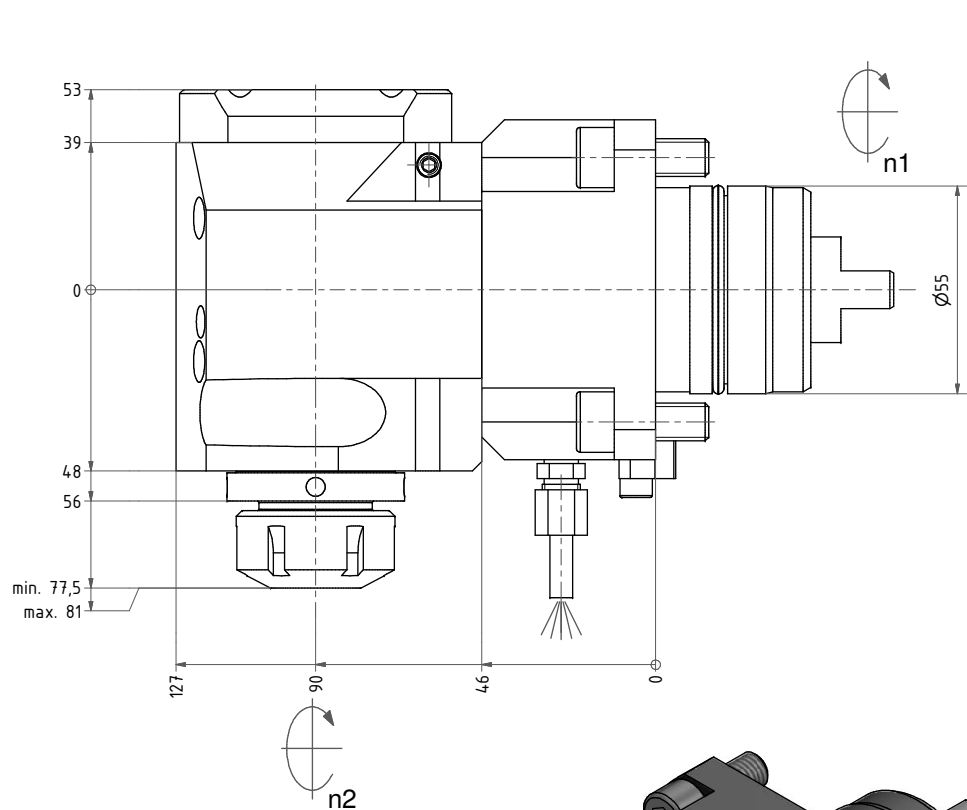
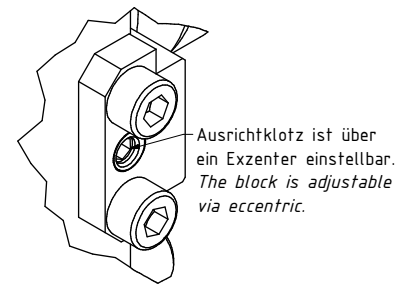



Ausrichtklotz ist über ein Exzenter einstellbar.
The block is adjustable via eccentric.



Hakenschlüssel mit Zapfen
Hook wrench with fixed pin
DIN1810 B 45x50



Spannzangenschlüssel
Clamping wrench
225

Bemerkung - Note 	Technische Daten - Technical data Weight = 6.652 [kg] Torque max. (M1/M2) = 50 / 50 [Nm] Speed max. (n1/n2) = 6000 / 6000 [1/min] Gear ratio (i)=n1:n2 = 1:1	Benennung - Title Radial Bohr und Fräskopf Radial drilling and milling head	 EWS Werkzeug GmbH & Co. KG D-72084 Löhningen www.ews-tool.de IDENT: DEWS020031 Nr. - No. 60.5525NEX906GLX90	Technische Änderungen vorbehalten! Subject to technical modifications! REV: -/A 158840 
--------------------------	--	---	---	--

Copyright EWS Tool Technologies
Weitergabe und Vervielfältigung dieser Unterlage, Verwertung und Mitteilung ihres Inhalts nicht gestattet, soweit nicht ausdrücklich zugestanden. Zuwiderhandlungen verpflichten zu Schadenersatz.