

EWS-Varia V5

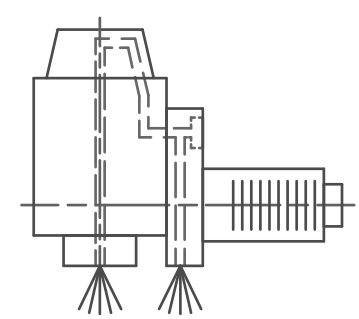
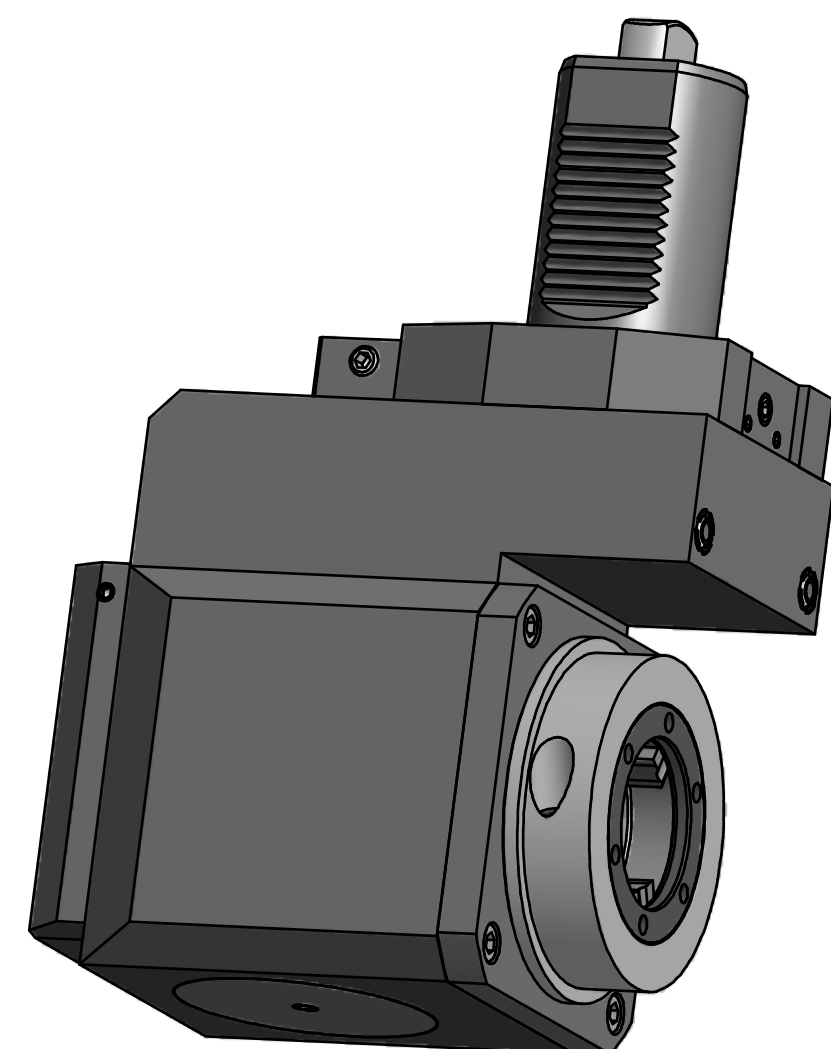

Innen- und Aussenkuehlung / Inside and outside coolant supply
 Kein Trockenlauf / No dry run
 Kuehlmittelfiltrierung50μ / coolant filtration50μ

Schutzrecht angemeldet
Trademark right applied

Benennung - Note
 Nicht ohne Kuehlmittel betreiben!
 Not for use without coolant-fluid!
 mit Kegelrollenlager
 with taper roller bearing(s)

Technische Daten - Technical data
 $M1 / M2 = 80 / 160 \text{ Nm}$
 $n1 / n2 = 4000 / 2000 \text{ 1/min}$
 $i (N1:N2) = 2:1$
 $P_{max} = 70 \text{ bar}$

Benennung - Title
Radial Bohr und Fräskopf. zurückges
Radial drill. and mill. head offset

name	date
Theiss	22.09.2011

EWS Weigle GmbH & Co. KG
 Maybachstr. 1
 D-70666 Uhlingen
 Tel. +49(0)7161/93040-10

Technische Aenderungen vorbehalten!
 Subject to technical modifications!
 Nr. **80.50V5KR1809RIK12**
 File: D-EWS-109484-.idw Blatt - page 1 (1)

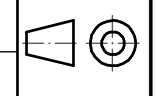

DIN A2