

Spannzange / collet ER25 DIN6499
 Spannbereich / clamping range: 1,0 - 16,0

Gewindebohrzange / tapping collet
 ET-1-25 M3-M10

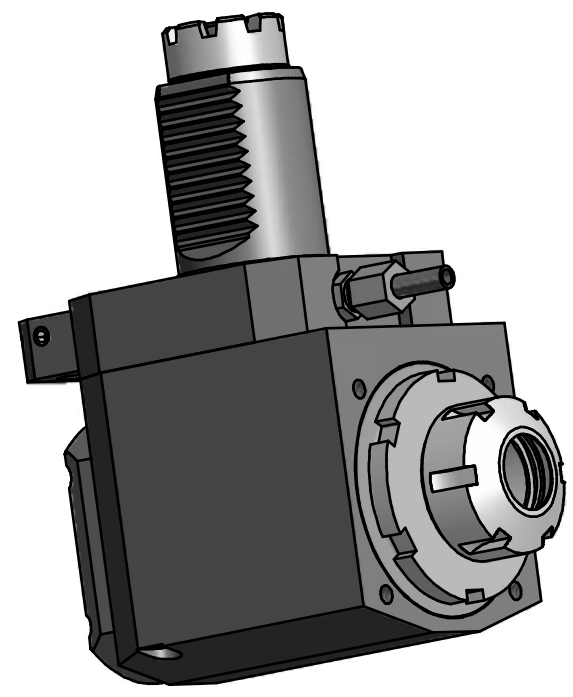
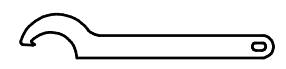

 Hakenschlüssel
 mit Nase
 Hook wrench with
 nose end
 DIN1810 A 58x62

 Spannzangenschlüssel
 Clamping wrench
 225

Copyright **EWS Tool Technologies**
 Weitergabe und Vervielfaeltigung dieser Unterlage,
 Verwertung und Mitteilung ihres Inhalts nicht
 gestattet, soweit nicht ausdruuecklich zugestanden.
 Zuwiderhandlungen verpflichten zu Schadenersatz.

Bemerkung - Note	Technische Daten - technical data M1 / M2 = 50 / 25 Nm n1 / n2 = 5000 / 10000 1/min i (N1:N2) = 1:2	Benennung - Title Radial Bohr und Fräskopf <i>Radial drilling and milling head</i>	<table border="1"> <tr> <th>name</th> <th>date</th> </tr> <tr> <td>drawing</td> <td>26.02.2007</td> </tr> </table>	name	date	drawing	26.02.2007	Technische Aenderungen vorbehalten! Subject to technical modifications! Nr. 60.4025TOEMR11 File: 60.4025TOEM11_OUT.idw	 DIN A3 Blatt - page 1 (1)
name	date								
drawing	26.02.2007								