

Schwenkbereich $\pm 105^\circ$
Swivel area $\pm 105^\circ$

Spannzange / collet ER25 DIN6499
Spannbereich / clamping range: 1,0 - 16,0

Gewindebohrzange / tapping collet
ET-1-25 M3-M10

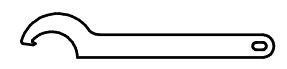
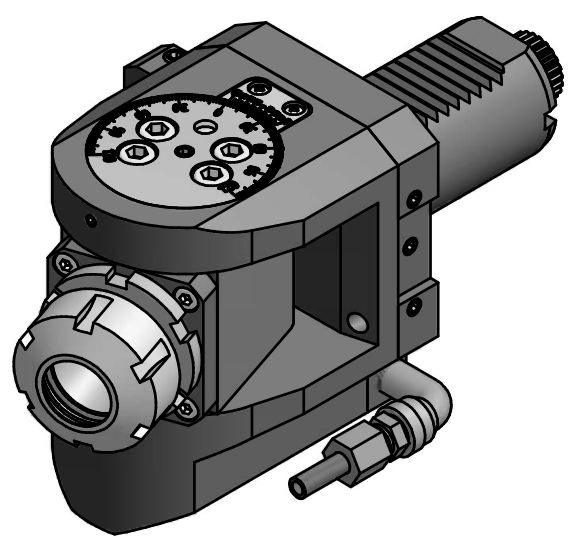

Hakenschlüssel
mit Nase
Hook wrench with
nose end
DIN1810 A 45x50



Spannzangenschlüssel
Clamping wrench
225

Copyright **EWS Tool Technologies**
Weitergabe und Vervielfaeltigung dieser Unterlage,
Verwertung und Mitteilung ihres Inhalts nicht
gestattet, soweit nicht ausdrecklich zugestanden.
Zuwiderhandlungen verpflichten zu Schadenersatz.

Bemerkung - Note	Technische Daten - technical data M1 / M2 = 20 / 20 Nm n1 / n2 = 10000/10000 1/min i (N1:N2) = 1:1	Benennung - Title Schwenkkopf Swivel head	<table border="1"> <tr> <th>name</th> <th>date</th> </tr> <tr> <td>Theiss</td> <td>10.09.2014</td> </tr> </table>	name	date	Theiss	10.09.2014	Technische Aenderungen vorbehalten! Subject to technical modifications! Nr. 63.4025CTXY18.6	 DIN A3
name	date								
Theiss	10.09.2014								
			Weigle GmbH & Co. KG Maybachstr. 1 D-73066 Uehingen Tel. +49(0)7161/93040-10	MNR: 156451 IDENT: D-EWS-162830 -	Blatt - page 1 (1)				