

Spannzange / collet ER25 DIN6499  
 Spannbereich / clamping range: 1,0 - 16,0

Gewindebohrzange / tapping collet  
 ET-1-25 M3-M10

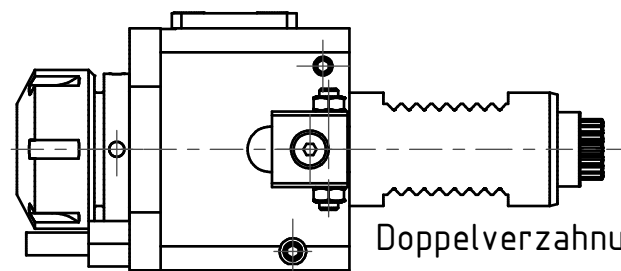

Doppelverzahnung Lizenz Traub  
 double tooth system licence Traub

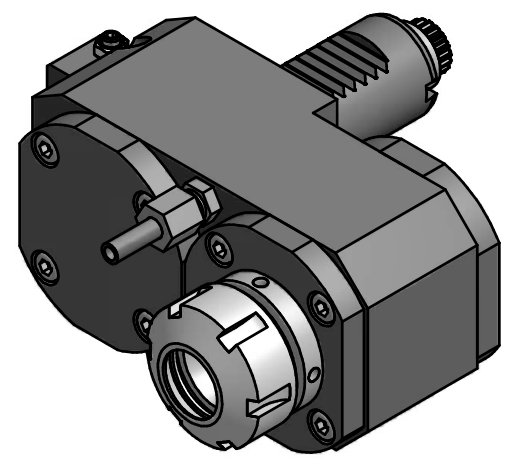

Spannzangenschlüssel  
 Clamping wrench  
 225



Hakenschlüssel  
 mit Zapfen  
 Hook wrench  
 with fixed pin  
 DIN1810 B 40x42

Copyright **EWS Tool Technologies**  
 Weitergabe und Vervielfaeltigung dieser Unterlage,  
 Verwertung und Mitteilung ihres Inhalts nicht  
 gestattet, soweit nicht ausdrecklich zugestanden.  
 Zuwiderhandlungen verpflichten zu Schadenersatz.

Bemerkung - Note	Technische Daten - technical data $M_1 / M_2 = 25 / 25 \text{ Nm}$ $n_1 / n_2 = 8000 / 8000 \text{ 1/min}$ $i (N_1:N_2) = 1:1$	Benennung - Title <b>Axial Bohr u. Fräskopf achsversetzt</b> <b>Ax. drill. and mill. head offset</b>	<table border="1"> <tr> <th>name</th> <th>date</th> </tr> <tr> <td>drawing</td> <td>16.02.2007</td> </tr> </table>	name	date	drawing	16.02.2007	Technische Aenderungen vorbehalten! Subject to technical modifications! Nr. <b>50.3025CTXRL</b> MNR: 127562 IDENT: D-EWS-003498 A Blatt - page 1 (1)	
name	date								
drawing	16.02.2007								