

Spannzange / collet ER25 DIN6499
 Spannungsbereich / clamping range: 1,0 - 16,0

Gewindebohrzange / tapping collet
 ET-1-25 M3-M10

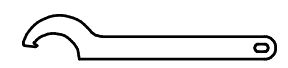

Hakenschlüssel
 mit Nase
 Hook wrench with
 nose end
 DIN1810 A 45x50

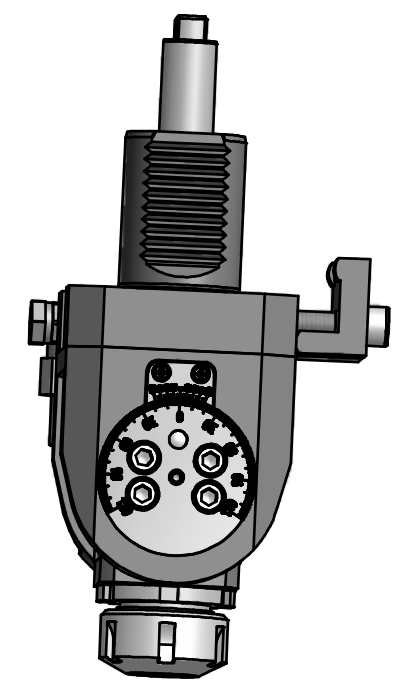
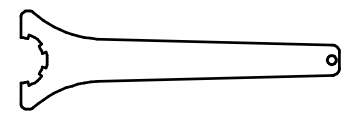

Spannzangenschlüssel
 Clamping wrench
 225

Copyright **EWS Tool Technologies**
 Weitergabe und Vervielfältigung dieser Unterlage,
 Verwertung und Mitteilung ihres Inhalts nicht
 gestattet, soweit nicht ausdrücklich zugestanden.
 Zuwiderhandlungen verpflichten zu Schadenersatz.

Bemerkung - Note	Technische Daten - technical data M1 / M2 = 20 / 20 Nm n1 / n2 = 6000 / 6000 1/min i (N1:N2) = 1:1	Benennung - Title Schwenkkopf <i>Swivel head</i>	<table border="1"> <thead> <tr> <th></th> <th>name</th> <th>date</th> </tr> </thead> <tbody> <tr> <td>drawing</td> <td>Schmid</td> <td>14.03.2007</td> </tr> </tbody> </table>		name	date	drawing	Schmid	14.03.2007	Technische Änderungen vorbehalten! Subject to technical modifications! Nr. 63.4025180928M File: 63.4025180928M_OUT.idw Blatt - page 1 (1)
	name	date								
drawing	Schmid	14.03.2007								

