

Spannzange / collet ER32 DIN6499  
Spannbereich / clamping range: 2,0 - 20,0

Gewindebohrzange / tapping collet  
ET-1-32 M5-M12

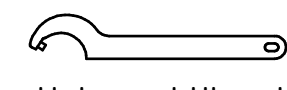

Hakenschlüssel  
mit Zapfen  
Hook wrench  
with fixed pin  
DIN1810 B 45x50

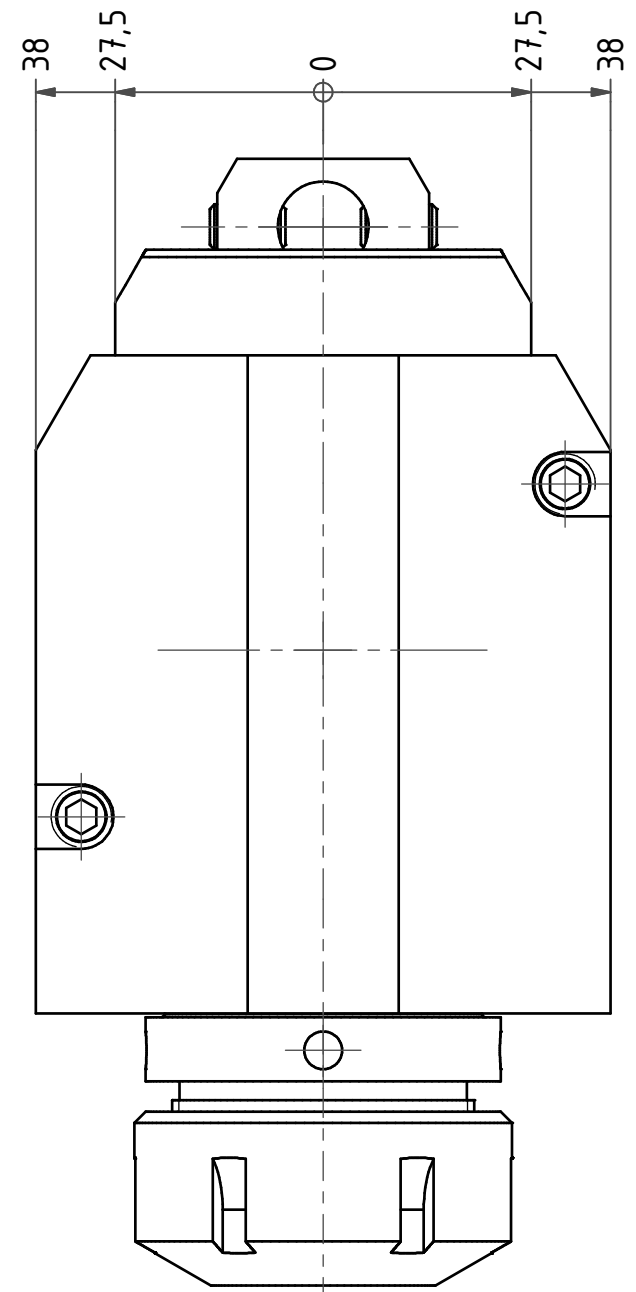
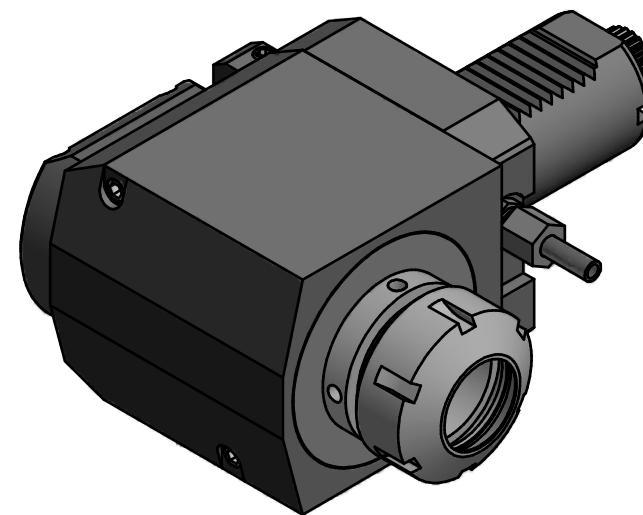
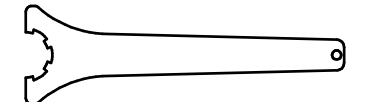

Spannzangenschlüssel  
Clamping wrench  
232

Copyright **EWS Tool Technologies**  
Weitergabe und Vervielfaeltigung dieser Unterlage,  
Verwertung und Mitteilung ihres Inhalts nicht  
gestattet, soweit nicht ausdrecklich zugestanden.  
Zuwiderhandlungen verpflichten zu Schadenersatz.

Bemerkung - Note

Technische Daten - technical data

Weight	= 5.194 [kg]
Torque max. (M1/M2)	= 50 / 50 [Nm]
Speed max. (n1/n2)	= 6000 / 6000 [1/min]
Gear ratio (i)=n1:n2	= 1:1

Benennung - Title

**Radial Bohr und Fräskopf**  
**Radial drilling and milling head**

**EWS**  
Tool Technologies

EWS Weigele GmbH & Co. KG  
Maybachstr. 1  
D-73066 Uhingen  
www.ews-tools.de

Nr. - No.  
**60.4032KCTXRGL**

Technische Aenderungen vorbehalten!  
Subject to technical modifications!

IDENT: D-EWS-210871

REV: -/-

MNR.  
**123691**

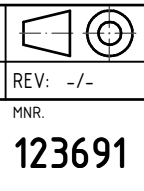

QR