

Spannzange / collet ER40 DIN6499
 Spannbereich / clamping range: 3,0 - 26,0

Gewindebohrzange / tapping collet
 ET-1-40 M6-M16

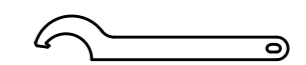

Hakenschlüssel
 mit Nase
 Hook wrench with
 nose end
 DIN1810 A 80x90

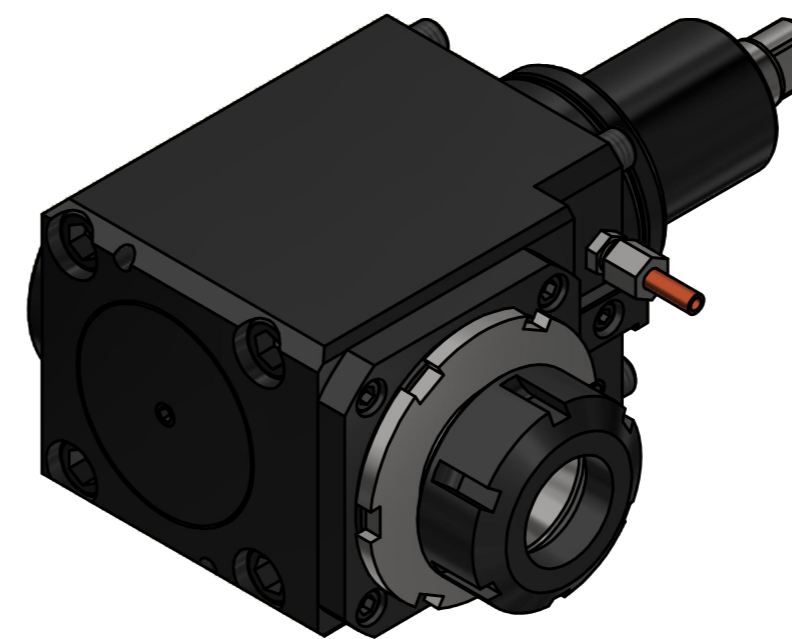
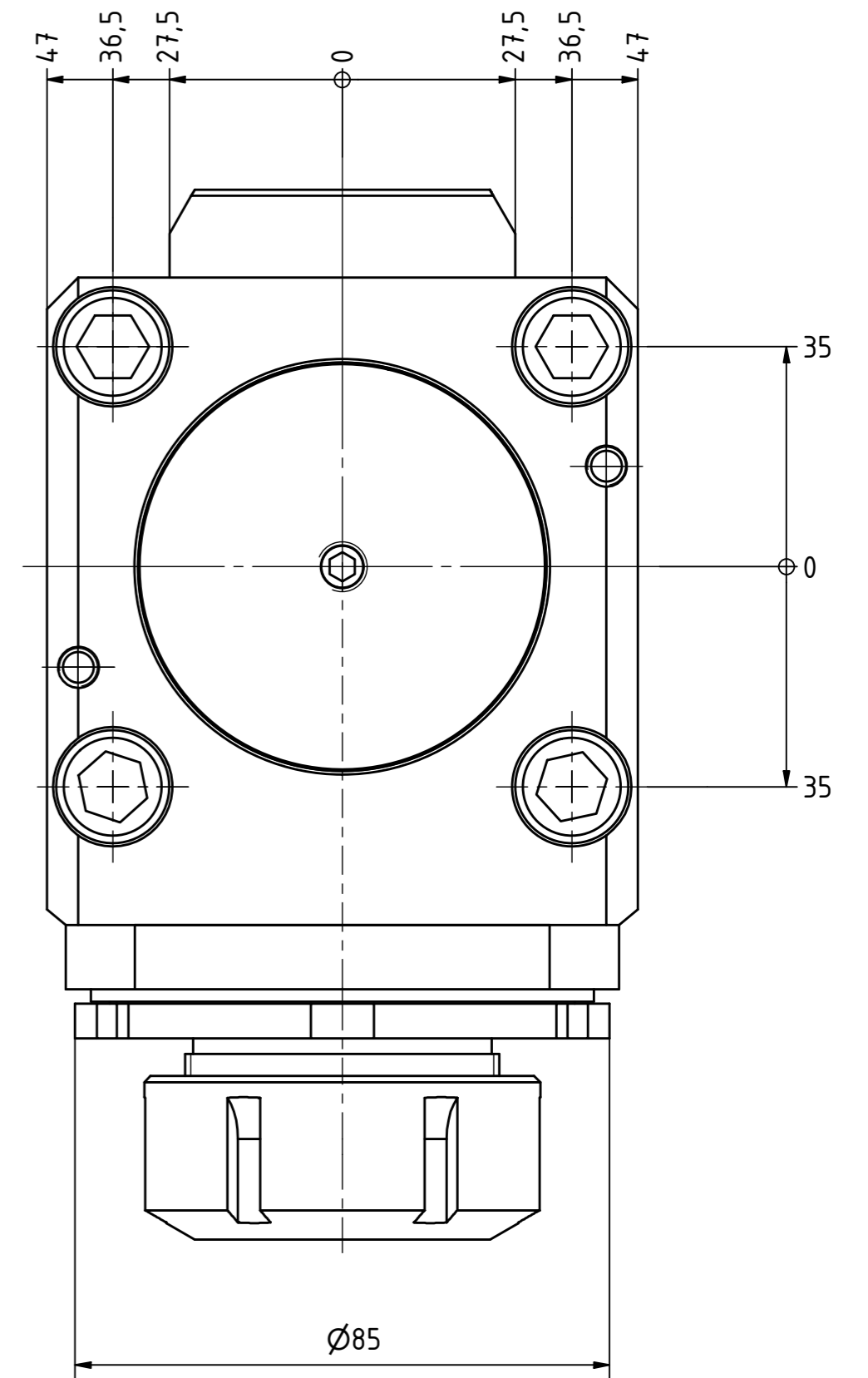
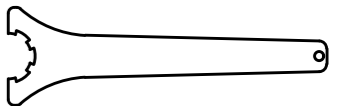

Spannzangenschlüssel
 Clamping wrench
 240

Copyright **EWS Tool Technologies**
 Weitergabe und Vervielfältigung dieser Unterlage,
 Verwertung und Mitteilung ihres Inhalts nicht
 gestattet, soweit nicht ausdrücklich zugestanden.
 Zuwiderhandlungen verpflichten zu Schadenersatz.

Bemerkung - Note	Technische Daten - technical data Weight = 10.066 [kg] Torque max. (M1/M2) = 40 / 80 [Nm] Speed max. (n1/n2) = 6000 / 3000 [1/min] Gear ratio (i)=n1:n2 = 2:1	Benennung - Title Radial Bohr und Fräskopf Radial drilling and milling head	EWS EWS Weigle GmbH & Co. KG Maybachstr. 1 D-73066 Ulm/Ingen www.ews-tool.de	Technische Änderungen vorbehalten! Subject to technical modifications! IDENT: DEWS149774 Nr. - No. 60.654-01809DW0212GLX80	REV: -/E MNR. 159902	
------------------	---	---	--	---	-------------------------	--