

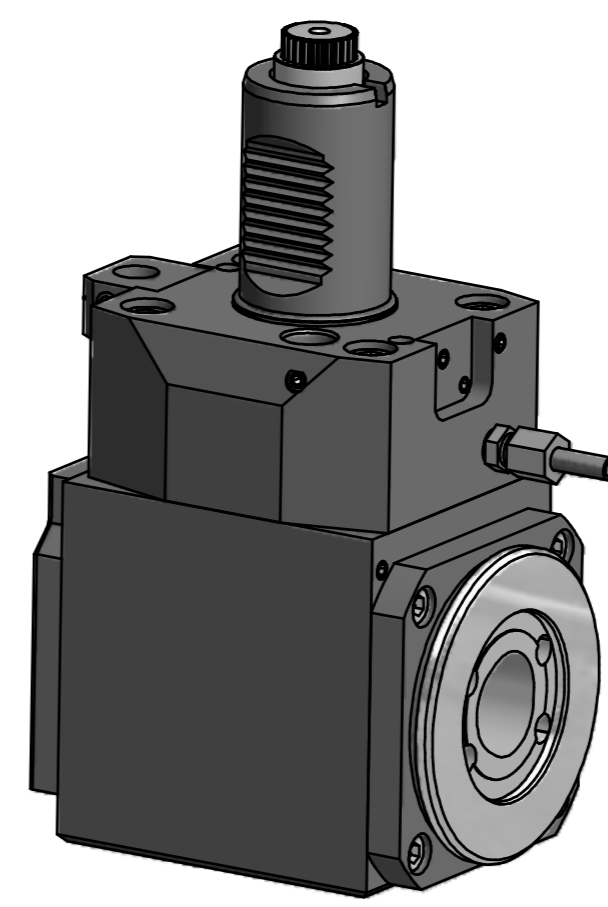

Doppelverzahnung Lizenz Traub
double tooth system licence Traub

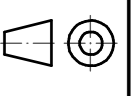

Copyright **EWS Tool Technologies**
Weitergabe und Vervielfältigung dieser Unterlage,
Verwertung und Mitteilung ihres Inhalts nicht
gestattet, soweit nicht ausdrücklich zugestanden.
Zuwendungen verpflichten zu Schadenersatz.

| | | | | | | | |
|------------------|---|---|---|------------|---|---|----------------------------|
| Bemerkung - Note | Technische Daten - Technical data M ₁ / M ₂ = 50 / 50 Nm n ₁ / n ₂ = 6000 / 6000 1/min i (N ₁ :N ₂) = 1:1 | Benennung - Title Radial Bohr und Fräskopf <i>Radial drilling and milling head</i> | name | date | Technische Änderungen vorbehalten! Subject to technical modifications! |  DIN A2 | |
| | | | drawing | 27.02.2007 | | | Nr. 60.40C4CTXRL |
| | | |  EWS Werkzeug GmbH & Co. KG Maybachstr. 1 D-73066 Ulm/Gen Tel. +49(0)7161/93040-100 | | MNR: 124639 | IDENT: D-EWS-004882 - | Blatt - page 1 (1) |