

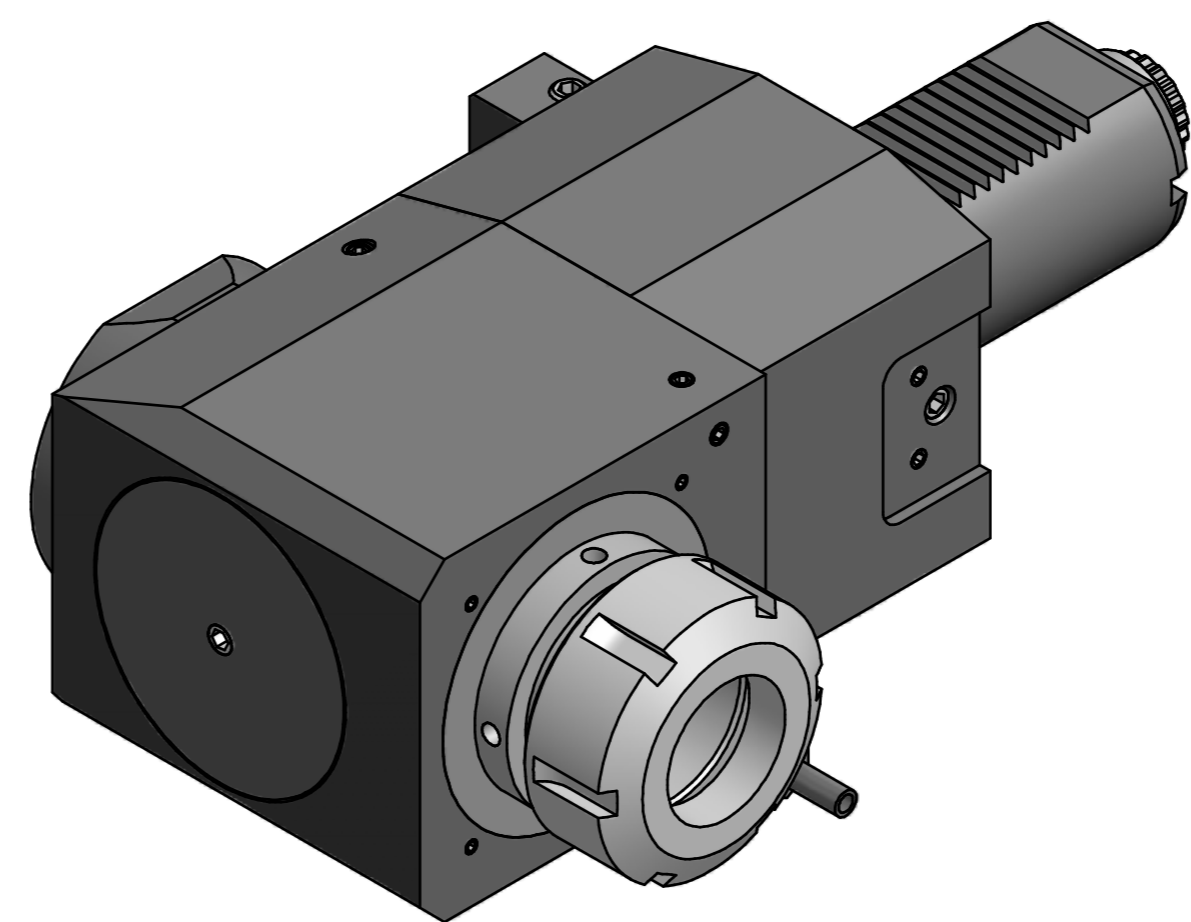

Spannzange / collet ER40 DIN6499
Spannbereich / clamping range: 3,0 - 26,0



Gewindebohrzange / tapping collet
ET-1-40 M6-M16



Hakenschlüssel
mit Zapfen
Hook wrench
with fixed pin
DIN1810 B 58x62

Spannzangenschlüssel
Clamping wrench
240

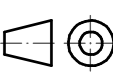
Copyright **EWS Tool Technologies**
Weitergabe und Vervielfältigung dieser Unterlage,
Verwertung und Mitteilung ihres Inhalts nicht
gestattet, soweit nicht ausdrücklich zugestanden.
Zuwendungen verpflichten zu Schadenersatz.

Bemerkung - Note	Technische Daten - Technical data M ₁ / M ₂ = 100 / 100 Nm n ₁ / n ₂ = 4000 / 4000 1/min i (N ₁ :N ₂) = 1:1	Benennung - Title Radial Bohr und Fräskopf <i>Radial drilling and milling head</i>	name	date	Technische Änderungen vorbehalten! Subject to technical modifications!	 DIN A2
			drawing	Theiss		
			 Weigete GmbH & Co. KG Maybachstr. 1 D-73066 Uhingen Tel. +49(0)7161/93040-10		Nr. 60.5040L5480RGLX125	
			File: D-EWS-123650-ldw		Blatt - page 1 (1)	