

Hydrodehnfutter / hydraulic chuck NBC-12/16-40

Hülsen / collets 28.12xxHYDSP

XX (Ø)	3	4	5	6	7	8	9	10
	1/8	3/16	1/4	5/16	3/8			

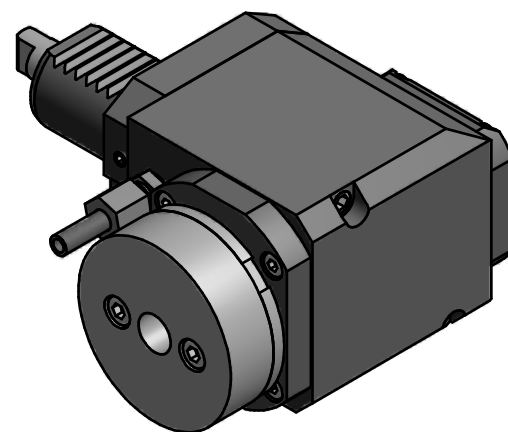
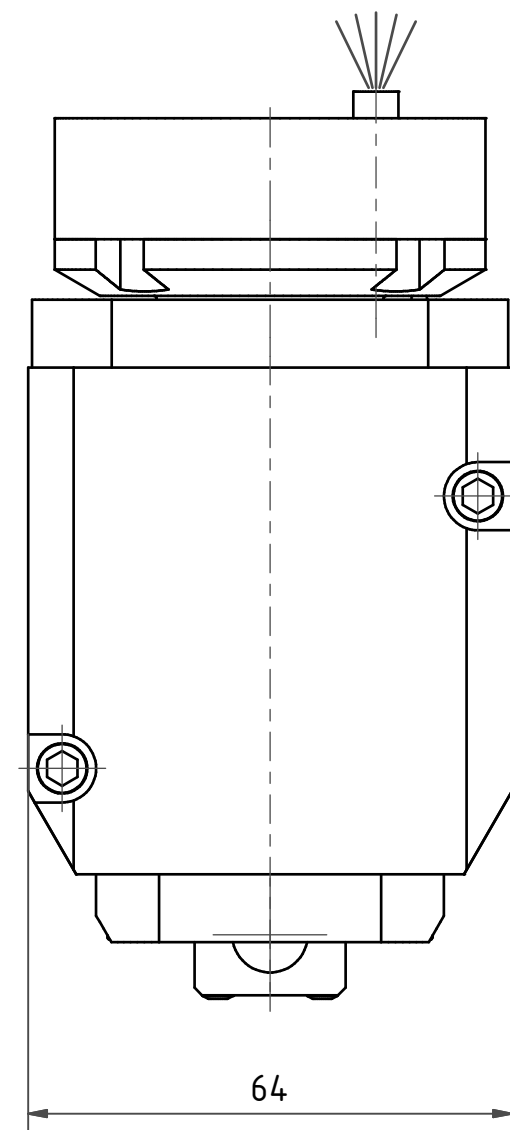
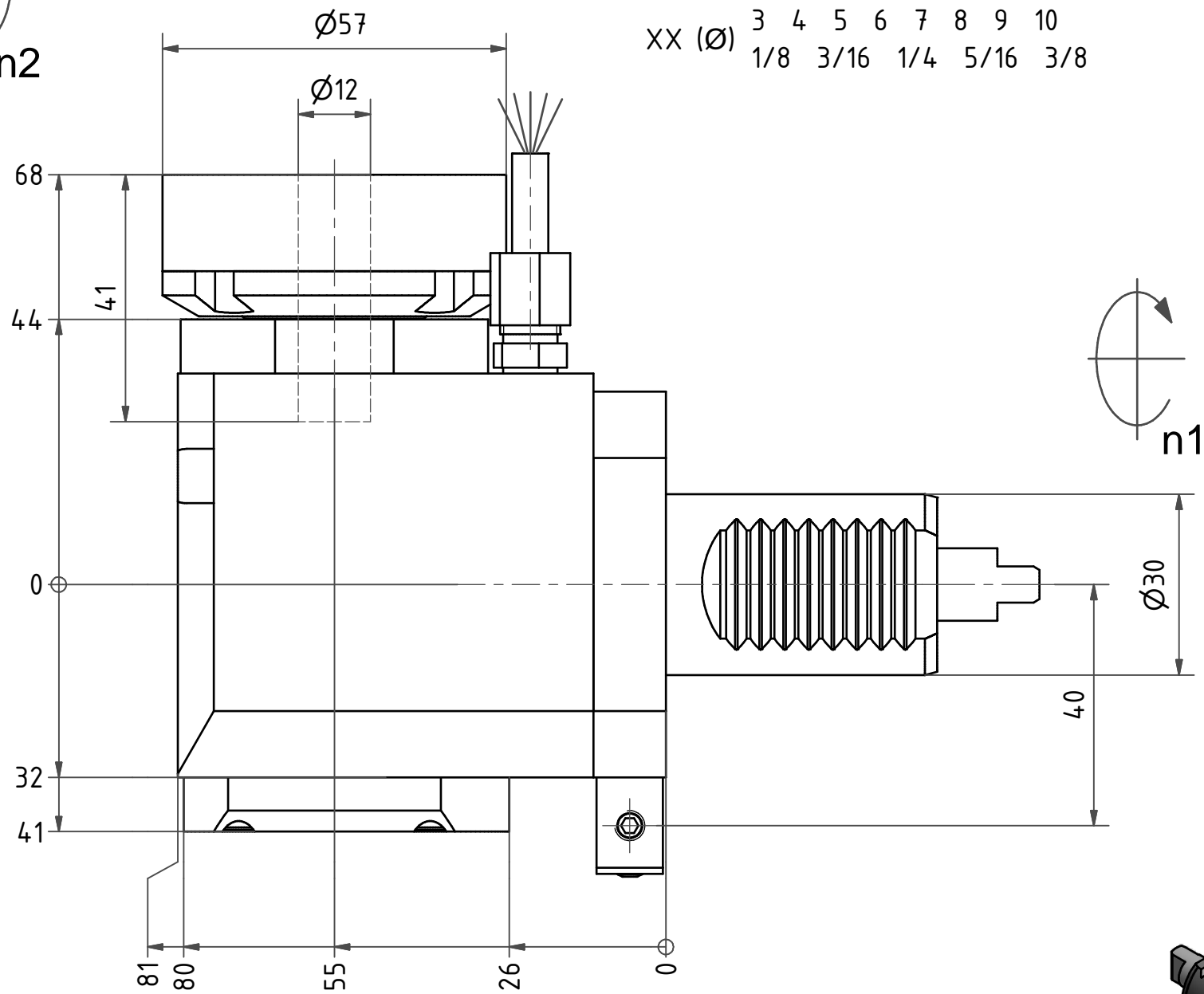
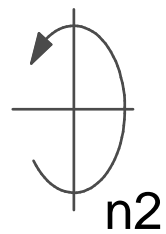

Copyright **EWS Tool Technologies**
 Weitergabe und Vervielfaeltigung dieser Unterlage,
 Verwertung und Mitteilung ihres Inhalts nicht
 gestattet, soweit nicht ausdruücklich zugestanden.
 Zuwiderhandlungen verpflichten zu Schadenersatz.

Bemerkung - Note

Technische Daten - technical data
 Weight = 3.116 [kg]
 Torque max. (M1/M2) = 24 / 12 [Nm]
 Speed max. (n1/n2) = 6000 / 12000 [1/min]
 Gear ratio (i)=n1:n2 = 1:2

Benennung - Title
Radial Bohr und Fräskopf
Radial drilling and milling head

EWS Tool Technologies
 EWS Weigele GmbH & Co. KG
 Maybachstr. 1
 D-73066 Uthingen
 www.ews-tools.de
 Nr. - No.
60.3012HYD1809L11

Technische Aenderungen vorbehalten!
 Subject to technical modifications!
 IDENT: D-EWS-108394
 MNR.
156241

REV: A/-

