

Spannzange / collet ER40 DIN6499
 Spannbereich / clamping range: 3,0 - 26,0

Gewindebohrzange / tapping collet
 ET-1-40 M6-M16

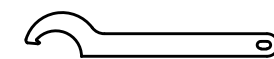

Hakenschlüssel
 mit Nase
 Hook wrench with
 nose end
 DIN1810 A 80x90

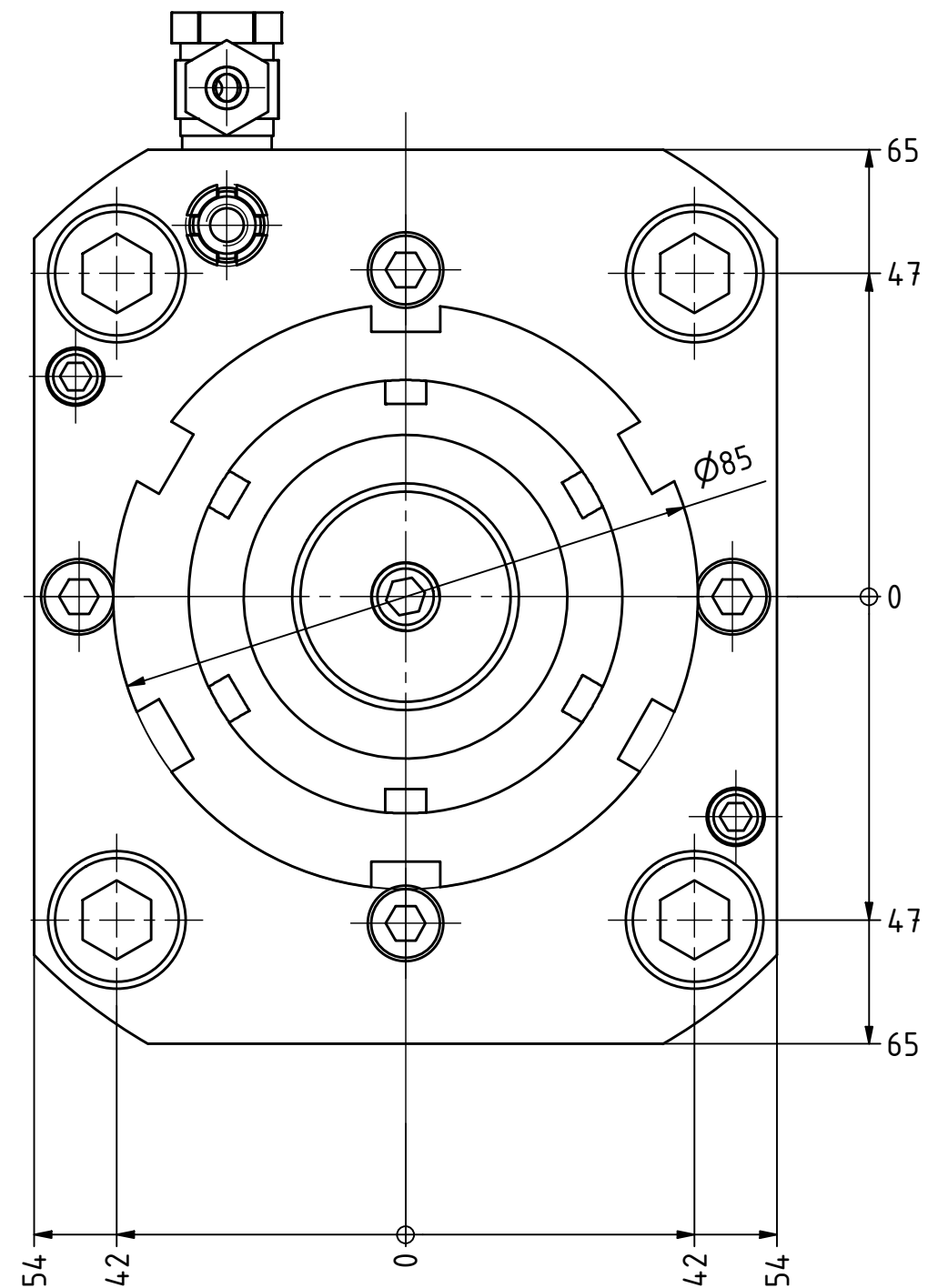
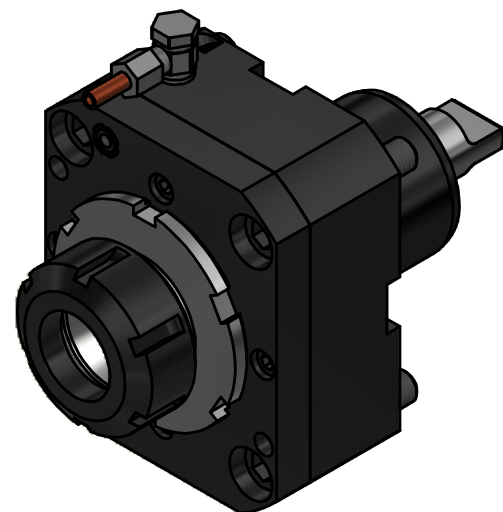
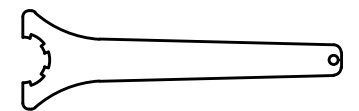

Spannzangenschlüssel
 Clamping wrench
 240

Copyright **EWS Tool Technologies**
 Weitergabe und Vervielfältigung dieser Unterlage,
 Verwertung und Mitteilung ihres Inhalts nicht
 gestattet, soweit nicht ausdrücklich zugestanden.
 Zuwiderhandlungen verpflichten zu Schadenersatz.

Bemerkung - Note

Technische Daten - technical data

Benennung - Title

Weight = 7.223 [kg]
 Torque max. (M1/M2) = 100 / 100 [Nm]
 Speed max. (n1/n2) = 6000 / 6000 [1/min]
 Gear ratio (i)=n1:n2 = 1:1

Axial Bohr und Fräskopf
Axial drilling and milling head



Nr. - No.
40.6040NL

Technische Änderungen vorbehalten!
 Subject to technical modifications!

IDENT: DEWS150305

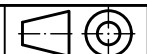

REV: -/F

MNR.
125401

