

Capto C5-Aufnahme
Capto C5-Adaptor

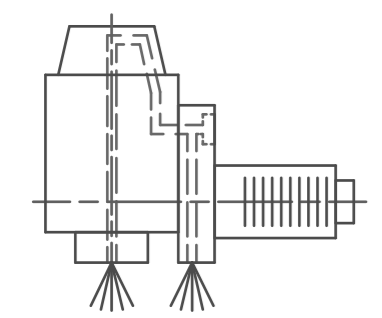
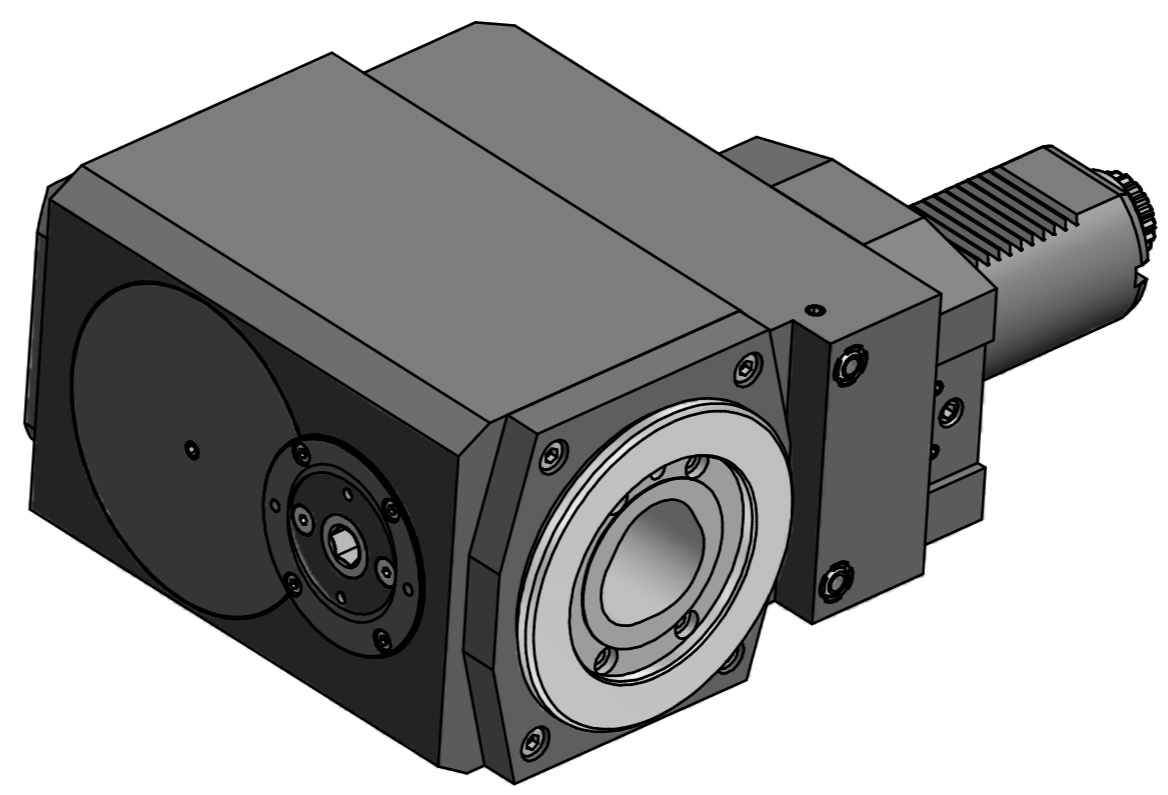
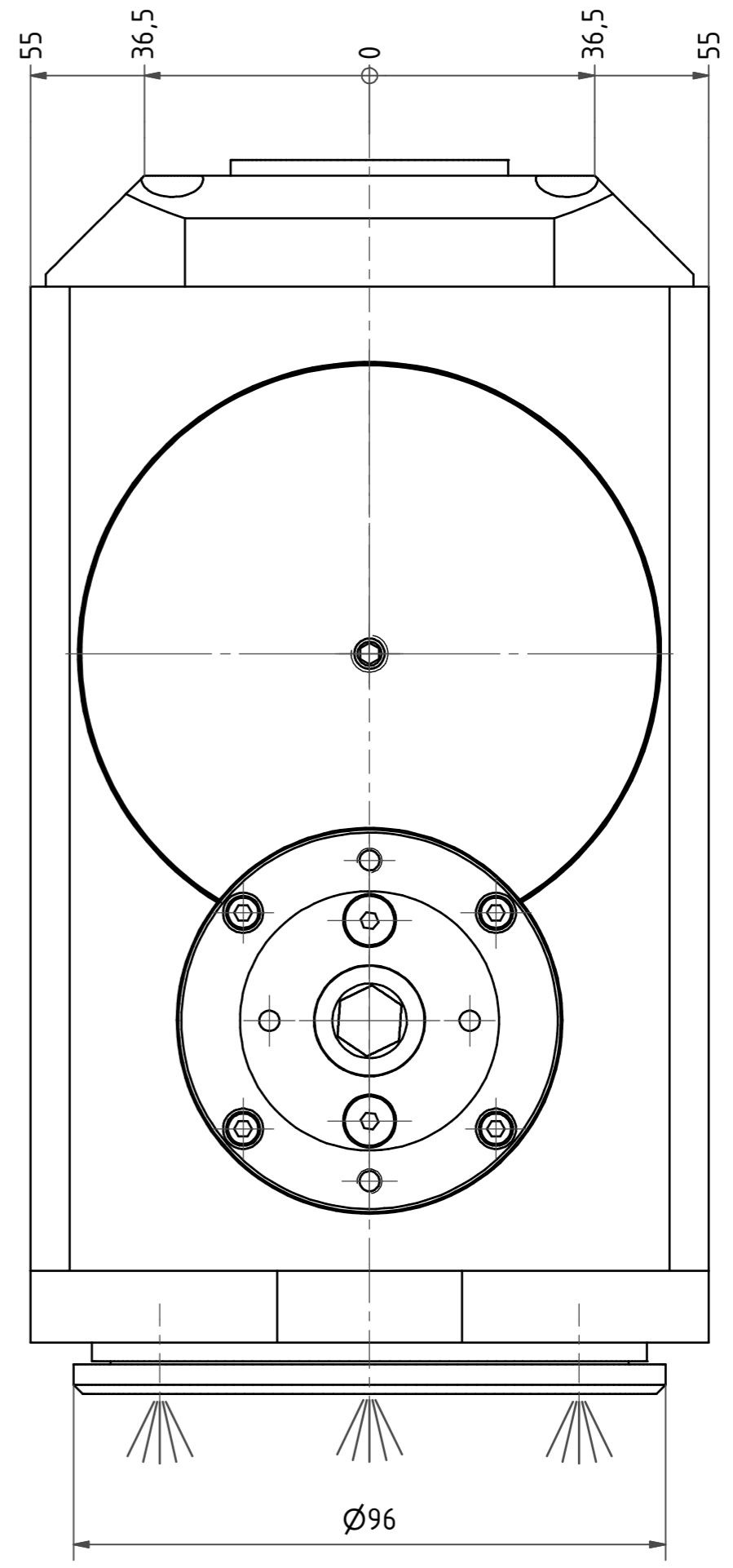
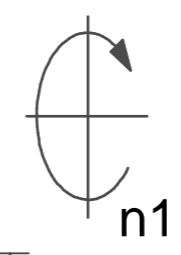
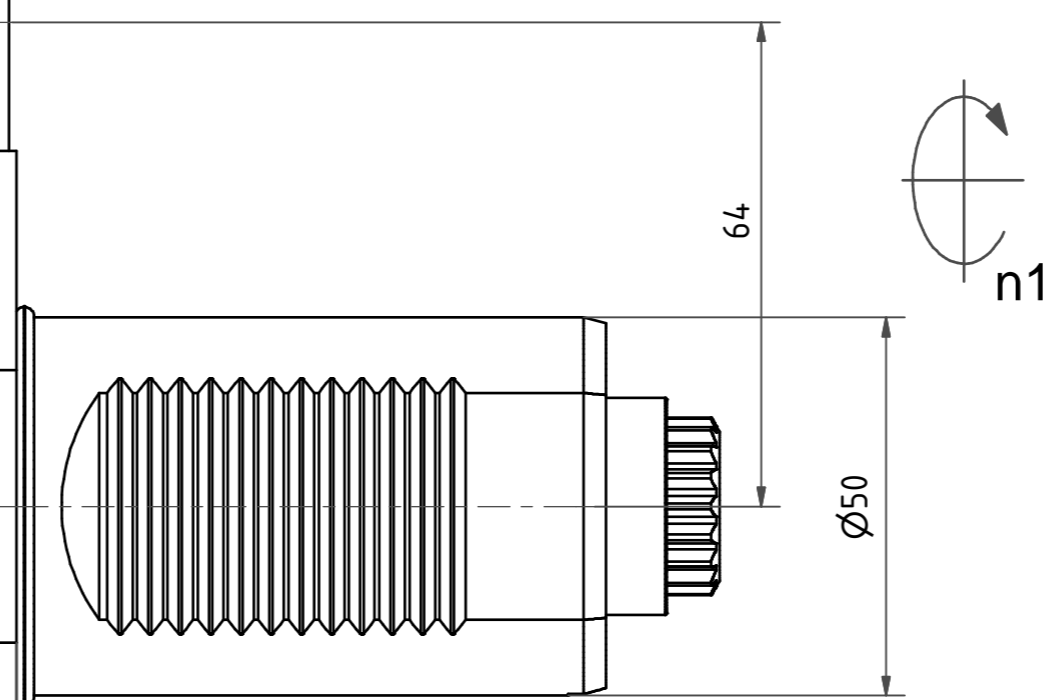
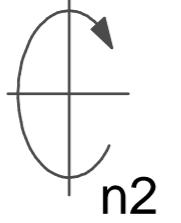

Innen- und Aussenkuehlung / Inside and outside coolant supply
Kein Trockenlauf / No dry run
Kuehmittelfiltrierung-50µ / coolant filtration-50µ

Bemerkung - Note
Nicht ohne Kuehlmittel betreiben!
Not for use without coolant-fluid!

Technische Daten - Technical data
M1 / M2 = 100 / 100 Nm
n1 / n2 = 4000 / 4000 1/min
i (N1:N2) = 1:1
Pmax = 70 bar

Benennung - Title
Radial Bohr und Fräskopf
Radial drilling and milling head

name	date
Sigel	13.10.2011

Technische Aenderungen vorbehalten!
Subject to technical modifications!

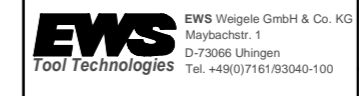

Nr. 60.50C55480RIKGLZ50

MNR: 156035 IDENT: D-EWS-110234 - Blatt - page 1 (1)

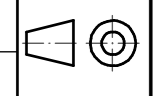

DIN A2

Copyright EWS Tool Technologies
Weitergabe und Vervielfaeltigung dieser Unterlage,
Verwertung und Mitteilung ihres Inhalts nicht
gestattet, soweit nicht ausdrecklich zugestanden.
Zuwaiderhandlungen verpflichten zu Schadenersatz.