

min. 80,5
max. 84

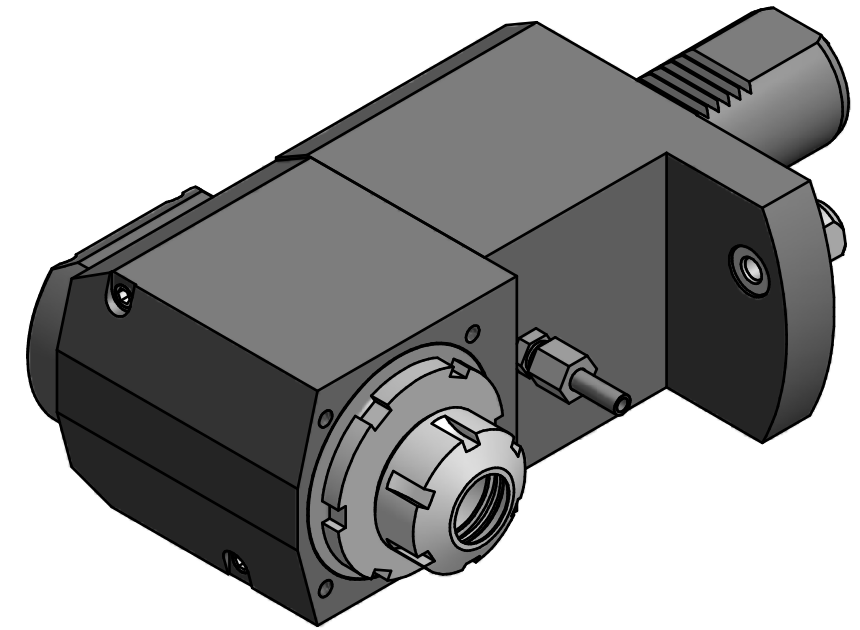

Spannzange / collet ER25 DIN6499
Spannbereich / clamping range: 1,0 - 16,0

Gewindebohrzange / tapping collet
ET-1-25 M3-M10



Hakenschlüssel
mit Zapfen
Hook wrench
with fixed pin
DIN1810 B 45x50

Spannzangenschlüssel
Clamping wrench
225

Copyright **EWS Tool Technologies**
Weitergabe und Vervielfältigung dieser Unterlage,
Verwertung und Mitteilung ihres Inhalts nicht
gestattet, soweit nicht ausdrücklich zugestanden.
Zuwiderhandlungen verpflichten zu Schadenersatz.

Bemerkung - Note	Technische Daten - technical data M1 / M2= 50 /25 Nm n1 / n2 = 6000 /12000 1/min i (N1:N2) = 1:2	Benennung - Title Radial Bohr und Fräskopf <i>Radial drilling and milling head</i>	<table border="1"> <tr> <td>name</td> <td>date</td> </tr> <tr> <td>Schmid</td> <td>16.03.2007</td> </tr> </table>	name	date	Schmid	16.03.2007	Technische Aenderungen vorbehalten! Subject to technical modifications! Nr. 60.4025MP620RI1 MNR: 125232 IDENT: D-EWS-012505 A Blatt - page 1 (1)
name	date							
Schmid	16.03.2007							