

Spannzange / collet ER32 DIN6499
 Spannbereich / clamping range: 2,0 - 20,0

Gewindebohrzange / tapping collet
 ET-1-32 M5-M12

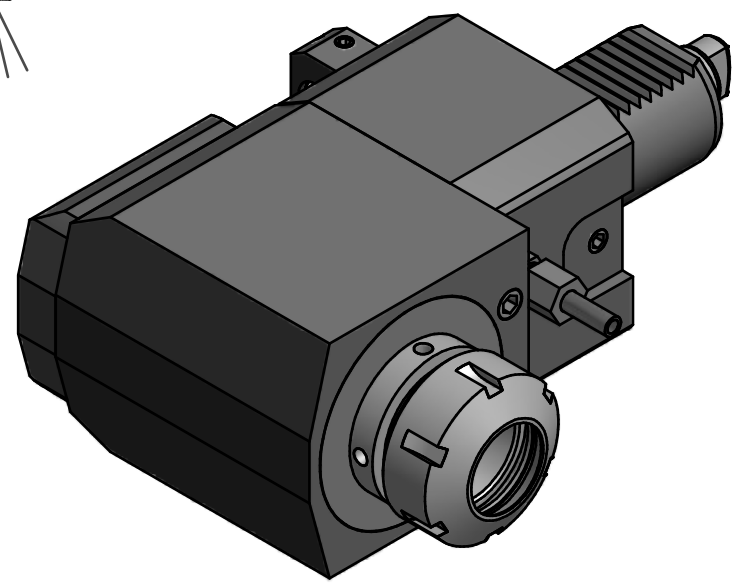

Spannzangenschlüssel
 Clamping wrench
 232

Hakenschlüssel
 mit Zapfen
 Hook wrench
 with fixed pin
 DIN1810 B 45x50

Copyright **EWS Tool Technologies**
 Weitergabe und Vervielfaeltigung dieser Unterlage,
 Verwertung und Mitteilung ihres Inhalts nicht
 gestattet, soweit nicht ausdrecklich zugestanden.
 Zuwiderhandlungen verpflichten zu Schadenersatz.

Bemerkung - Note	Technische Daten - technical data $M1 / M2 = 40 / 80 \text{ Nm}$ $n1 / n2 = 6000 / 3000 \text{ 1/min}$ $i (N1:N2) = 2:1$	Benennung - Title Radial Bohr und Fräskopf <i>Radial drilling and milling head</i>	<table border="1"> <tr> <th>name</th> <th>date</th> </tr> <tr> <td>drawing</td> <td>08.02.2007</td> </tr> </table>	name	date	drawing	08.02.2007	Technische Aenderungen vorbehalten! Subject to technical modifications! Nr. 60.40321809R12X100	
name	date								
drawing	08.02.2007								
			EWS Weigete GmbH & Co. KG Maybachstr. 1 D-73066 Uhlingen Tel. +49(0)7161/93040-100	MNR: 127220 IDENT: D-EWS-000806 - Blatt - page 1 (1)					