

Spannzange / collet ER32 DIN6499
 Spannbereich / clamping range: 2,0 - 20,0

Gewindebohrzange / tapping collet
 ET-1-32 M5-M12

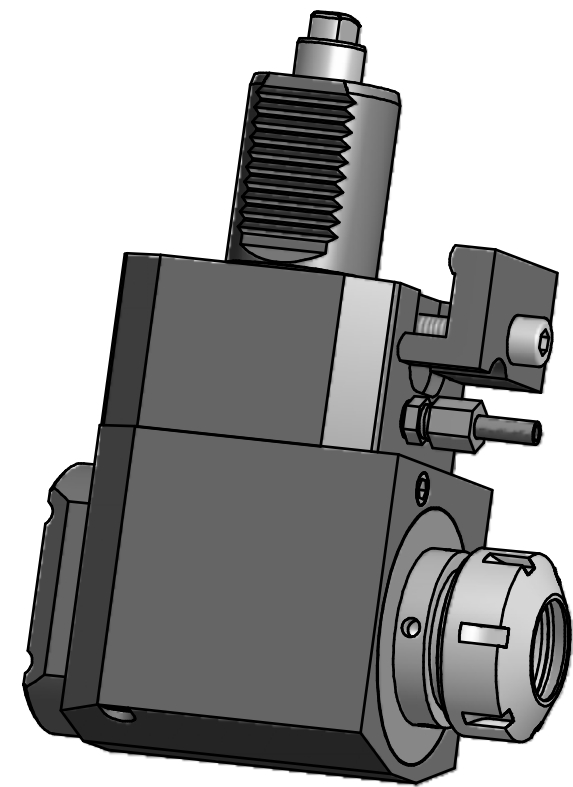

Copyright **EWS Tool Technologies**
 Weitergabe und Vervielfaeltigung dieser Unterlage,
 Verwertung und Mitteilung ihres Inhalts nicht
 gestattet, soweit nicht ausdrecklich zugestanden.
 Zuwiderhandlungen verpflichten zu Schadenersatz.

Bemerkung - Note	Technische Daten - technical data M1 / M2 = 50 / 50 Nm n1 / n2 = 6000 / 6000 1/min i (N1:N2) = 1:1	Benennung - Title Radial Bohr und Fräskopf <i>Radial drilling and milling head</i>	<table border="1"> <tr> <td>name</td> <td>date</td> </tr> <tr> <td>drawing</td> <td>15.03.2007</td> </tr> </table> <p>EWS Weigele GmbH & Co. KG Maybachstr. 1 D-73066 Uhingen Tel. +49(0)7161/93040-10</p>	name	date	drawing	15.03.2007	Technische Aenderungen vorbehalten! Subject to technical modifications! Nr. 60.40321809ROT03X90 File: 60.40321809ROT03X90_OUT.idw Blatt - page 1 (1)
name	date							
drawing	15.03.2007							