

Spannzange / collet ER32 DIN6499
 Spannbereich / clamping range: 2,0 - 20,0

Gewindebohrzange / tapping collet
 ET-1-32 M5-M12

Doppelverzahnung Lizenz Traub
 double tooth system licence Traub

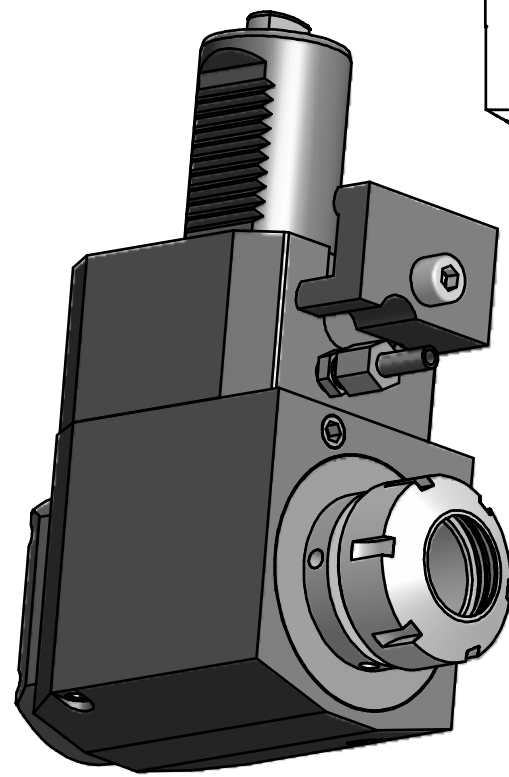

Copyright **EWS Tool Technologies**
 Weitergabe und Vervielfaeltigung dieser Unterlage,
 Verwertung und Mitteilung ihres Inhalts nicht
 gestattet, soweit nicht ausdruecklich zugestanden.
 Zuwiderhandlungen verpflichten zu Schadenersatz.

Bemerkung - Note	Technische Daten - technical data	Benennung - Title	<table border="1"> <tr> <th>name</th> <th>date</th> <th>Technische Aenderungen vorbehalten!</th> </tr> <tr> <td>drawing</td> <td>15.03.2007</td> <td>Subject to technical modifications!</td> </tr> </table>	name	date	Technische Aenderungen vorbehalten!	drawing	15.03.2007	Subject to technical modifications!	<table border="1"> <tr> <td>Nr.</td> <td rowspan="2"> 60.40321809RLOT03X90 </td> </tr> <tr> <td>File:</td> <td>60.40321809RLOT03X90_OUT.idw</td> </tr> </table>	Nr.	60.40321809RLOT03X90	File:	60.40321809RLOT03X90_OUT.idw
	name			date	Technische Aenderungen vorbehalten!									
drawing	15.03.2007	Subject to technical modifications!												
Nr.	60.40321809RLOT03X90													
File:		60.40321809RLOT03X90_OUT.idw												
	M1 / M2 = 50 / 50 Nm n1 / n2 = 6000 / 6000 1/min i (N1:N2) = 1:1	Radial Bohr und Fräskopf <i>Radial drilling and milling head</i>	<table border="1"> <tr> <td colspan="2"> </td> </tr> <tr> <td colspan="2"> DIN A3 </td> </tr> </table>			DIN A3		Blatt - page 1 (1)						
DIN A3														