

Spannzange / collet ER40 DIN6499  
 Spannbereich / clamping range: 3,0 - 26,0

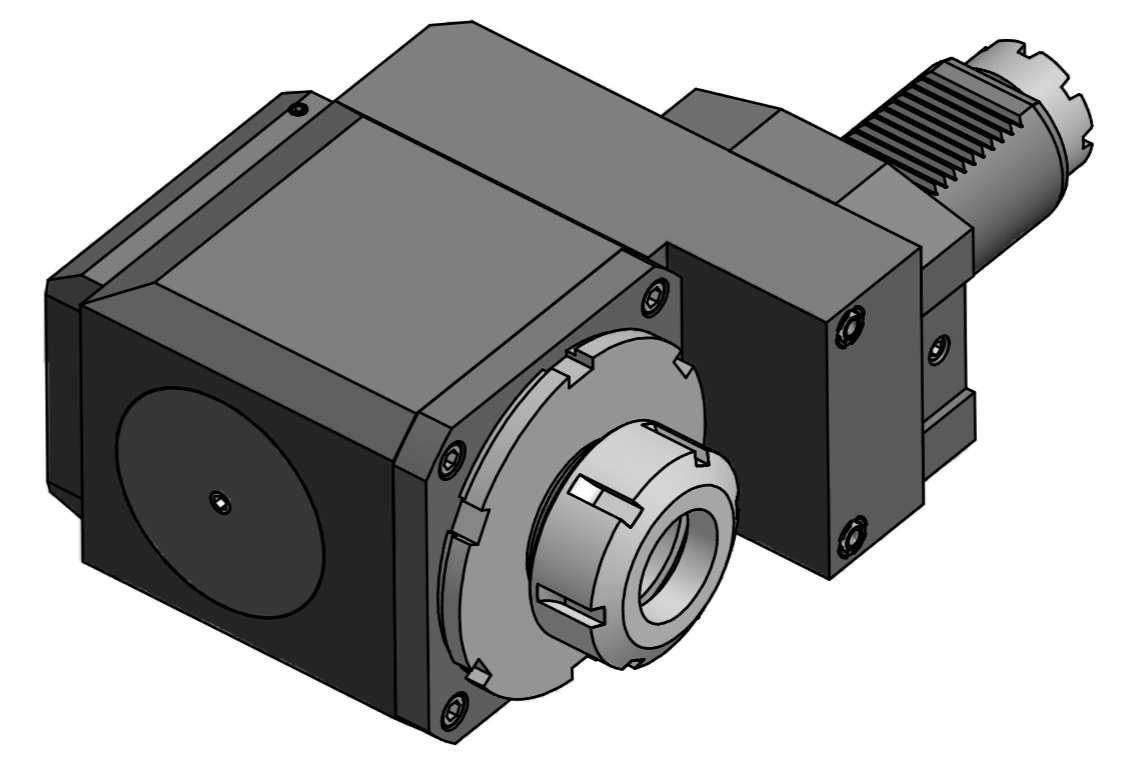

 Hakenschlüssel  
 mit Nase  
*Hook wrench with  
 nose end*  
 DIN1810 A 110x115

 Spannzangenschlüssel  
*Clamping wrench*  
 240

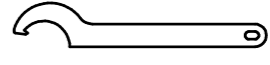
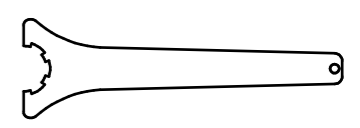
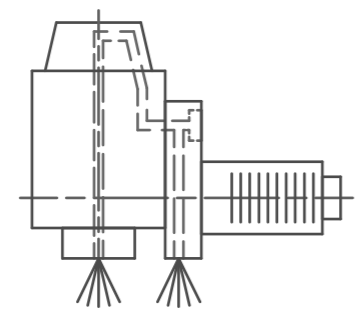

Innen- und Aussenkuehlung / Inside and outside coolant supply  
 Kein Trockenlauf / No dry run  
 Kuehlmittelfiltrierung=50µ / coolant filtration=50µ

<i>Bemerkung - Note</i>	<i>Technische Daten - Technical data</i>
<b>Nicht ohne Kuehlmittel betreiben!</b> <i>Not for use without coolant-fluid!</i>	M1 / M2= 80 /160 Nm
mit Kegelrollenlager <i>with taper roller bearing(s)</i>	n1 / n2 = 4000 /2000 1/min
	i (N1:N2) = 2:1
	pmax = 70 bar

*Benennung - Title*  
**Radial Bohr und Fräskopf, zurückges**  
*Radial drill. and mill. head offset*

<i>name</i>	<i>date</i>	<i>Technische Änderungen vorbehalten!</i> <i>Subject to technical modifications!</i>
drawing Theiss	26.04.2011	
		Nr. <b>80.5040TOEMRIK12</b>
<small>Wiegelt GmbH &amp; Co. KG        Maybachstr. 1        D-73066 Ulm/ingen        Tel. +49(0)7161/93040-10</small>		Blatt - page 1 (1)

Copyright **EWS Tool Technologies**  
 Weitergabe und Vervielfaeltigung dieser Unterlage,  
 Verwertung und Mitteilung ihres Inhalts nicht  
 gestattet, soweit nicht ausdrecklich zugestanden.  
 Zuwiderhandlungen verpflichten zu Schadenersatz.

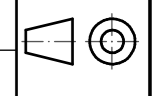

DIN A2