

Spannzange / collet ER40 DIN6499  
Spannbereich / clamping range: 3,0 - 26,0

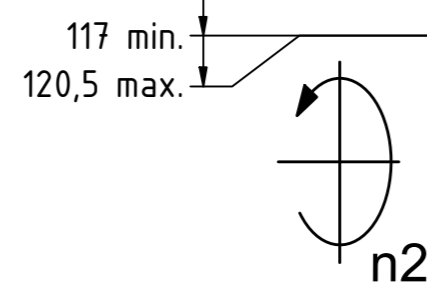

Ausrichtklotz ist über ein Exzenter einstellbar.  
The block is adjustable via eccentric.

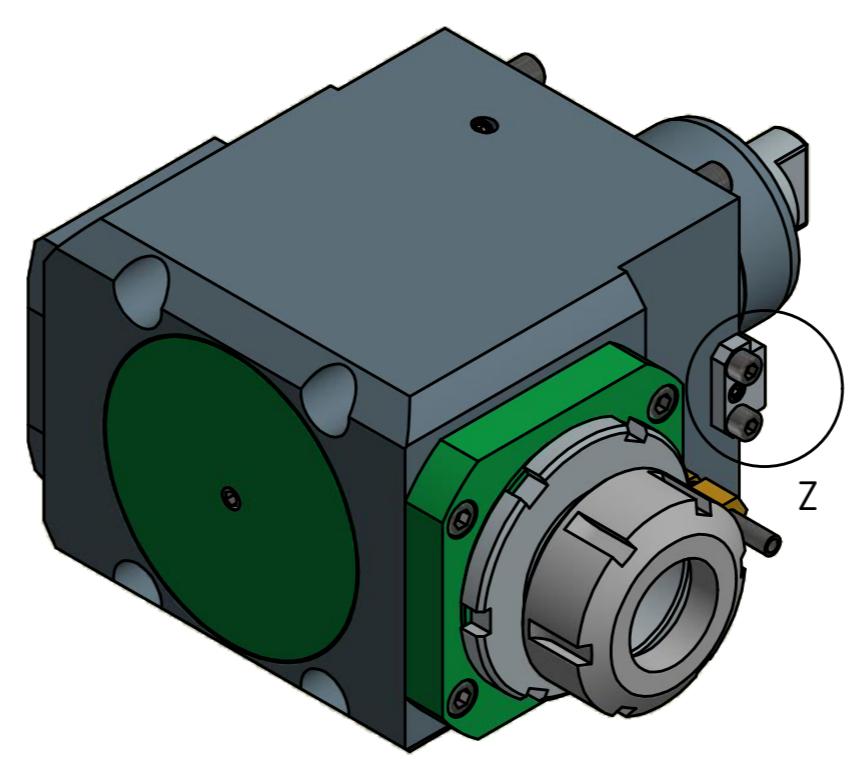
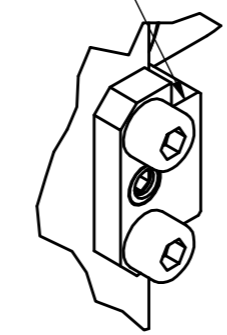

Hakenschlüssel mit Nase  
Hook wrench with nose end  
DIN1810 A 80x90

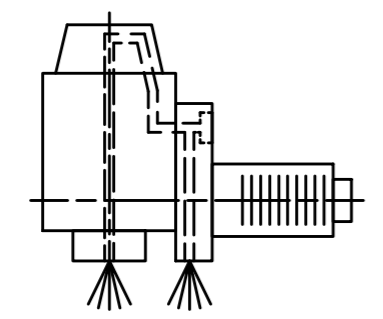

Innen- und Aussenkuehlung / Inside and outside coolant supply  
Kein Trockenlauf / No dry run  
Kuehlmittelfiltrierung-50µ / coolant filtration-50µ

Spannzangenschlüssel  
Clamping wrench  
240

Bemerkung - Note Nicht ohne Kuehlmittel betreiben! Not for use without coolant-fluid!	Technische Daten - technical data Weight = 15,174 [kg] Torque max. (M1/M2) = 100 / 100 [Nm] Speed max. (n1/n2) = 6000 / 6000 [1/min] Gear ratio (i)=n1:n2 = 1:1 Pressure (pmax) = 70 [bar]	Benennung - Title Radial Bohr und Fräskopf Radial drilling and milling head
---	---	---

EWS Weigle GmbH & Co. KG Maybachstr. 1 D-73066 Uhlingen www.ews-tool.de	Technische Aenderungen vorbehalten! Subject to technical modifications! IDENT: DEWS054205	MNR REV: -/D 154640
	Nr. - No. 60.6040NEX315IK	

Copyright EWS Tool Technologies  
Weitergabe und Vervielfaeltigung dieser Unterlage,  
Verwertung und Mitteilung ihres Inhalts nicht  
gestattet, soweit nicht ausdrecklich zugestanden.  
Zuwaerhandlungen verpflichten zu Schadenersatz.