

Spannzange / collet ER40 DIN6499
 Spannungsbereich / clamping range: 3,0 - 26,0

Gewindebohrzange / tapping collet
 ET-1-40 M6-M16

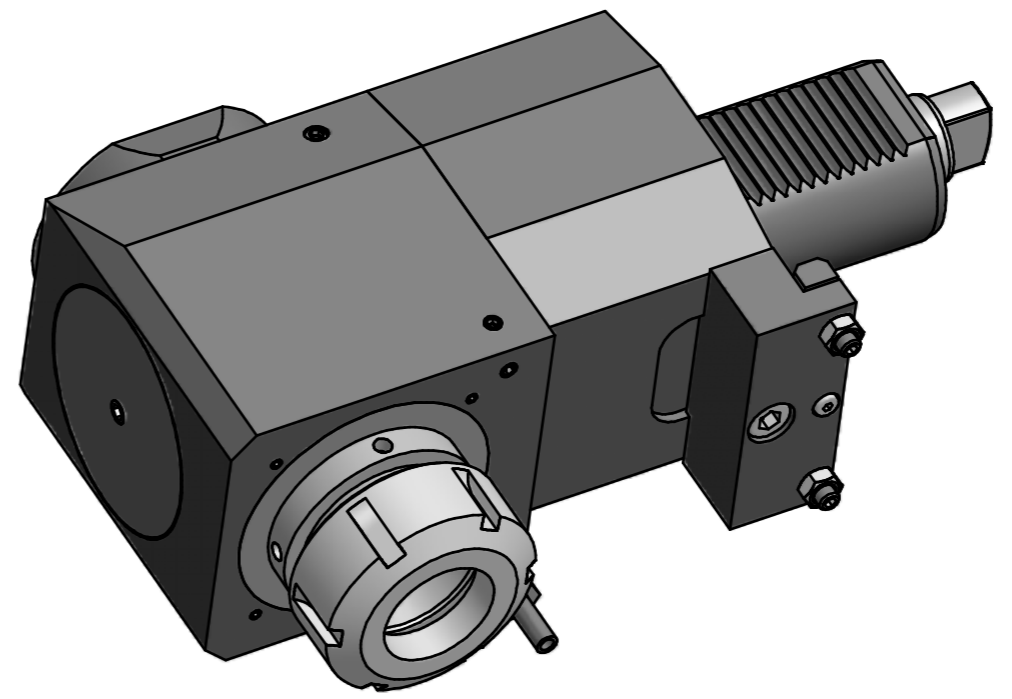
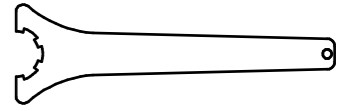

 Hakenschlüssel
 mit Zapfen
 Hook wrench
 with fixed pin
 DIN1810 B 58x62

 Spannzangenschlüssel
 Clamping wrench
 240

Copyright **EWS Tool Technologies**
 Weitergabe und Vervielfältigung dieser Unterlage,
 Verwertung und Mitteilung ihres Inhalts nicht
 gestattet, soweit nicht ausdrücklich zugestanden.
 Zuwiderhandlungen verpflichten zu Schadenersatz.

Benennung - Title	Technische Daten - Technical data		Benennung - Title	name	date	Technische Änderungen vorbehalten! Subject to technical modifications!	DIN A2	
	M ₁ / M ₂ = 100 / 100 Nm n ₁ / n ₂ = 4000 / 4000 1/min i (N ₁ :N ₂) = 1:1							Nr. 60.5040V740R
Benennung - Note				EWS EWS Werkzeug GmbH & Co. KG Maybachstr. 1 D-73066 Ulm/agen Tel. +49(0)7161/93040-100		MNR: 126207	IDENT: D-EWS-014413 -	Blatt - page 1 (1)