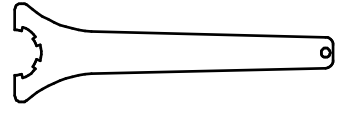

Trifix Anzugsdrehmoment 50 Nm
 Trifix clamping torque 50 Nm

max. 85
 min. 81,5

 Hakenschlüssel
 mit Zapfen
 Hook wrench
 with fixed pin
 DIN1810 B 45x50

 Spannzangenschlüssel
 Clamping wrench
 232

Spannzange / collet ER32 DIN6499
 Spannbereich / clamping range: 2,0 - 20,0

Gewindebohrzange / tapping collet
 ET-1-32 M5-M12

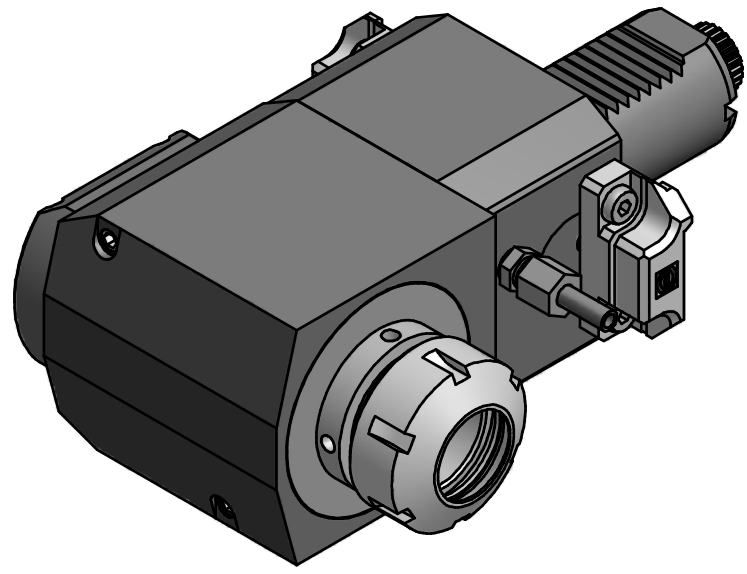

Copyright **EWS Tool Technologies**
 Weitergabe und Vervielfaeltigung dieser Unterlage,
 Verwertung und Mitteilung ihres Inhalts nicht
 gestattet, soweit nicht ausdrecklich zugestanden.
 Zuwiderhandlungen verpflichten zu Schadenersatz.

Bemerkung - Note 	Technische Daten - technical data M1 / M2 = 50 / 50 Nm n1 / n2 = 6000 / 6000 1/min i (N1:N2) = 1:1	Benennung - Title Radial Bohr und Fräskopf Radial drilling and milling head	<table border="1"> <tr> <td>name</td> <td>date</td> </tr> <tr> <td>M. Simoniello</td> <td>23.04.2013</td> </tr> </table>  EWS Weigle GmbH & Co. KG Maybachstr. 1 D-73066 Uhingen Tel. +49(0)7161/93040-100	name	date	M. Simoniello	23.04.2013	Technische Aenderungen vorbehalten! Subject to technical modifications! Nr. 60.4032CTXRTF MNR: 153425 IDENT: D-EWS-135450 - Blatt - page 1 (1)
name	date							
M. Simoniello	23.04.2013							