

Innen- und Aussenkuehlung / Inside and outside coolant supply
 Kein Trockenlauf / No dry run
 Kuehlmittelfiltrierung <math>< 50\mu</math> / coolant filtration <math>< 50\mu</math>

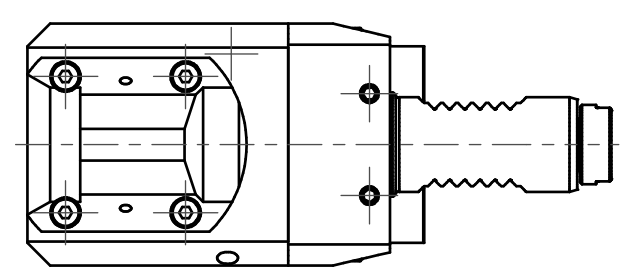

Doppelverzahnung Lizenz Traub
 double tooth system licence Traub

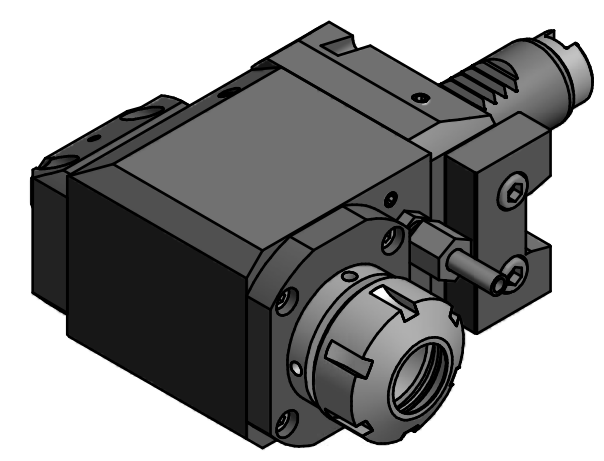

Hakenschlüssel
 mit Zapfen
 Hook wrench
 with fixed pin
 DIN1810 B 40x42

Spannzangenschlüssel
 Clamping wrench
 225

Copyright **EWS Tool Technologies**
 Weitergabe und Vervielfaeltigung dieser Unterlage,
 Verwertung und Mitteilung ihres Inhalts nicht
 gestattet, soweit nicht ausdruercklich zugestanden.
 Zuwiderhandlungen verpflichten zu Schadenersatz.

<p>Bemerkung - Note Nicht ohne Kuehlmittel betreiben! Not for use without coolant-fluid! mit Kegelrollenlager with taper roller bearing(s)</p>	<p>Technische Daten - technical data M1 / M2 = 25 / 25 Nm n1 / n2 = 6000 / 6000 1/min i (N1:N2) = 1:1 pmax = 70 bar</p>	<p>Benennung - Title Radial Bohr und Fräskopf Radial drilling and milling head</p>	<table border="1"> <tr> <th>name</th> <th>date</th> </tr> <tr> <td>Kratschmann</td> <td>09.06.2011</td> </tr> </table> <p>EWS EWS Weigle GmbH & Co. KG Maybachstr. 1 D-73066 Uhingen Tel. +49(0)7161/93040-100</p>	name	date	Kratschmann	09.06.2011	<p>Technische Aenderungen vorbehalten! Subject to technical modifications!</p> <p>Nr. 60.2525KRG200RLIKV</p> <p>MNR: 155259 IDENT: D-EWS-105305 A Blatt - page 1 (1)</p>
name	date							
Kratschmann	09.06.2011							