

Spannzange / collet ER25 DIN6499  
 Spannungsbereich / clamping range: 1,0 - 16,0

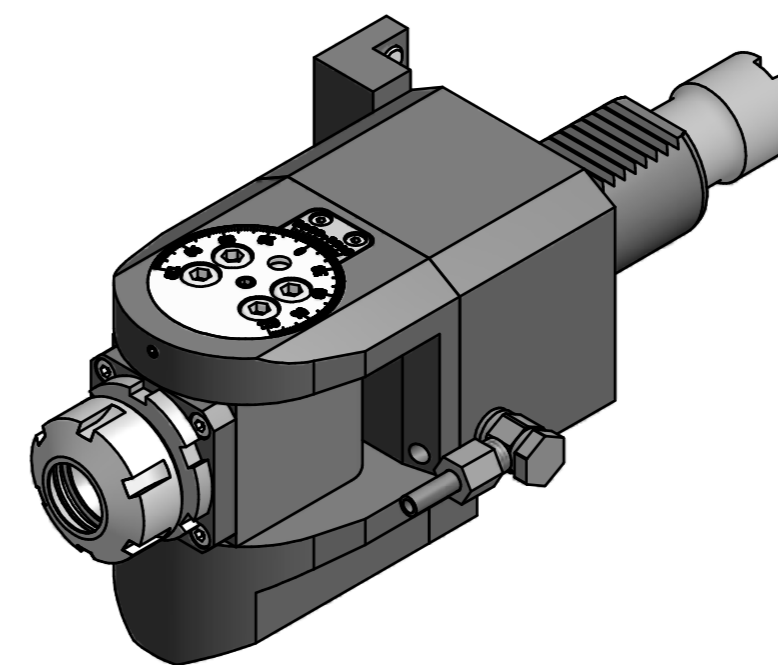

Gewindebohrzange / tapping collet  
 ET-1-25 M3-M10

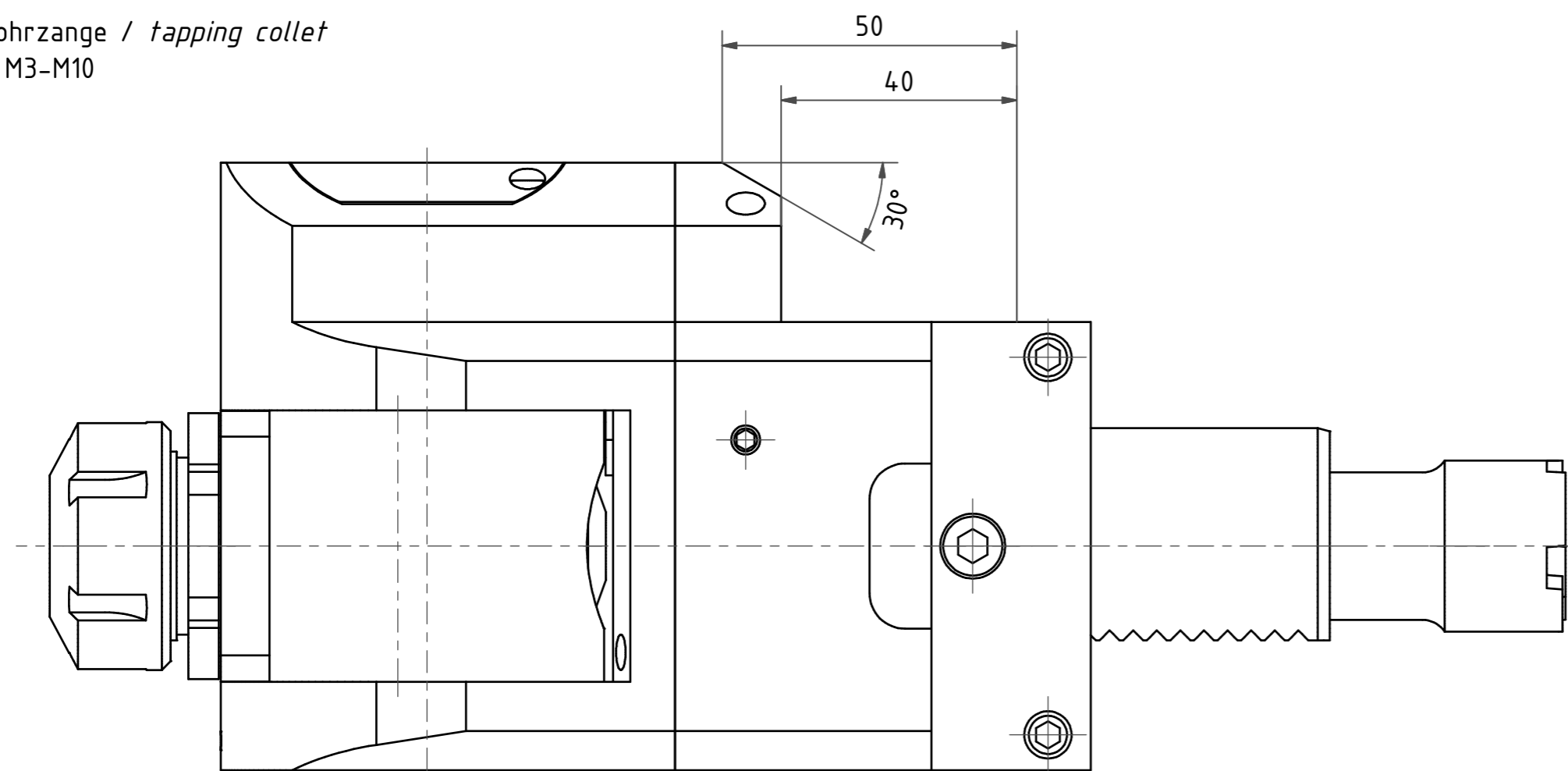

Hakenschlüssel  
 mit Nase  
 Hook wrench with  
 nose end  
 DIN1810 A 45x50

Spannzangenschlüssel  
 Clamping wrench  
 225

Copyright **EWS Tool Technologies**  
 Weitergabe und Vervielfältigung dieser Unterlage,  
 Verwertung und Mitteilung ihres Inhalts nicht  
 gestattet, soweit nicht ausdrücklich zugestanden.  
 Zuwiderhandlungen verpflichten zu Schadenersatz.

Bemerkung - Note  Schwenkbereich $\pm 105^\circ$ Swivel area $\pm 105^\circ$	Technische Daten - technical data Weight = 6.417 [kg] Torque max. (M1/M2) = 20 / 20 [Nm] Speed max. (n1/n2) = 6000 / 6000 [1/min] Gear ratio (i)=n1:n2 = 1:1	Benennung - Title  Schwenkkopf Swivel head	 EWS Weigle GmbH & Co. KG Maybachstr. 1 D-73066 Ulmringen www.ews-tools.de  Nr. - No. <b>63.4025LT15X100</b>	Technische Änderungen vorbehalten! Subject to technical modifications! IDENT: D-EWS-101200 MNR. <b>153414</b>	
---	--	---	---	---	---