

Spannzange / collet ER32 DIN6499
Spannbereich / clamping range: 2,0 - 20,0

Gewindebohrzange / tapping collet
ET-1-32 M5-M12

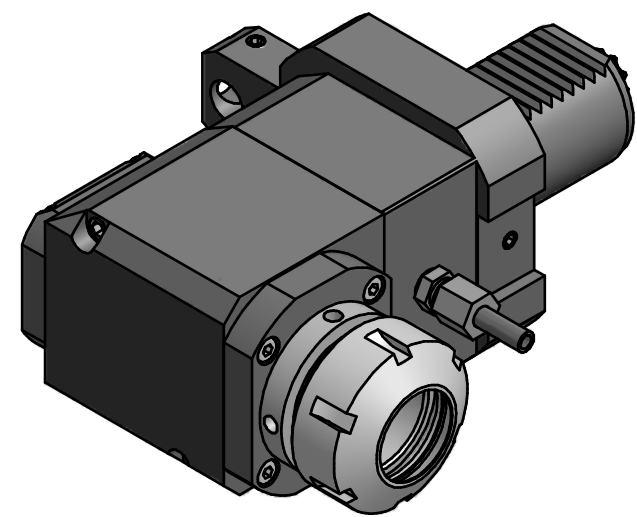

Hakenschlüssel
mit Zapfen
Hook wrench
with fixed pin
DIN1810 B 45x50

Spannzangenschlüssel
Clamping wrench
232

Copyright **EWS Tool Technologies**
Weitergabe und Vervielfältigung dieser Unterlage,
Verwertung und Mitteilung ihres Inhalts nicht
gestattet, soweit nicht ausdrücklich zugestanden.
Zu widerhandlungen verpflichten zu Schadenersatz.

| Bemerkung - Note | Technische Daten - technical data M1 / M2= 25 / 25 Nm n1 / n2 = 6000 / 6000 1/min i (N1:N2) = 1:1 | Benennung - Title Radial Bohr und Fräskopf <i>Radial drilling and milling head</i> | <table border="1"> <tr> <th>name</th> <th>date</th> </tr> <tr> <td>Theiss</td> <td>13.07.2010</td> </tr> </table> | name | date | Theiss | 13.07.2010 | Technische Aenderungen vorbehalten! Subject to technical modifications! Nr. 60.40325482RX90-BG30 |  DIN A3 MNR: 150741 IDENT: D-EWS-091223 - Blatt - page 1 (1) |
|------------------|--|---|---|------|------|--------|------------|--|---|
| name | date | | | | | | | | |
| Theiss | 13.07.2010 | | | | | | | | |