

Spannzange / collet ER25 DIN6499
 Spannereich / clamping range: 1,0 - 16,0

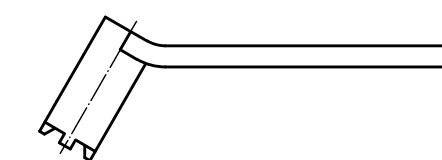

Schlüssel für Ausrichtung
 im Lieferumfang enthalten.
 Wrench for adjustment
 included in delivery
 AZS-LT2000

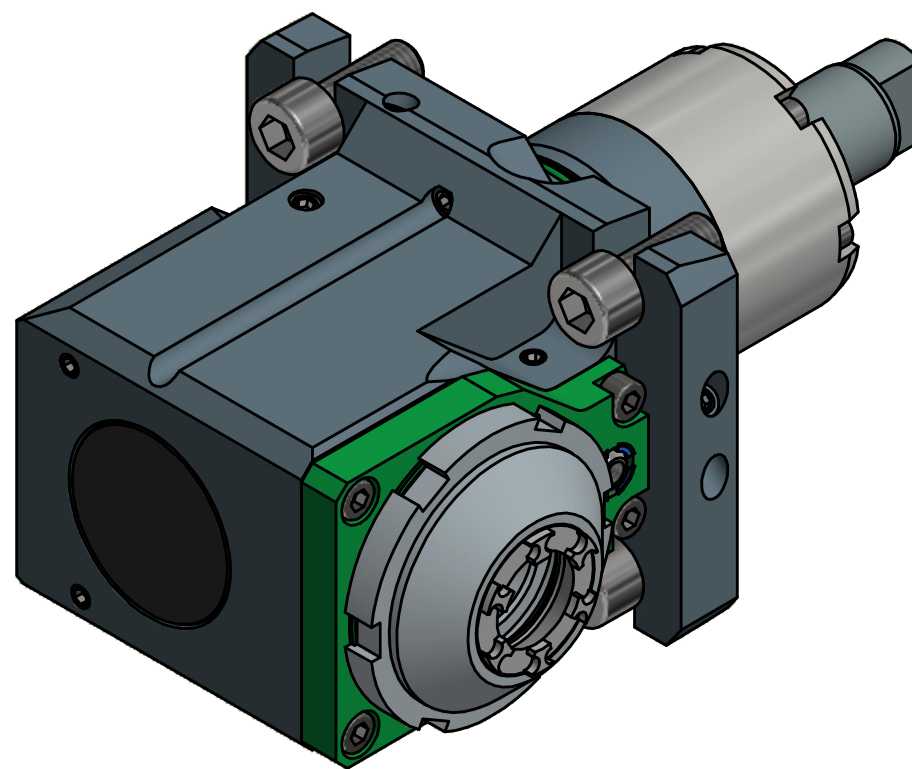
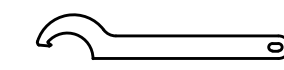

Hakenschlüssel
 mit Nase
 Hook wrench with
 nose end
 DIN1810 A 58x62

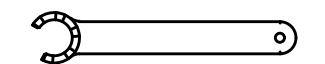

Spannzangenschlüssel für
 innenliegende Mutter
 Clamping wrench for
 internal collet
 225AX

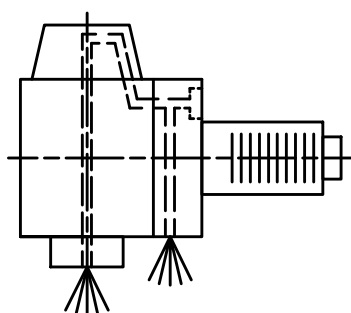

Innen- und Auskühlung / Inside and outside coolant supply
 Kühlmittelfiltrierung 50μ / coolant filtration 50μ

Copyright **EWS Tool Technologies**
 Weitergabe und Vervielfältigung dieser Unterlage,
 Verwertung und Mitteilung ihres Inhalts nicht
 gestattet, soweit nicht ausdrücklich zugestanden.
 Zuwiderhandlungen verpflichten zu Schadenersatz.

Bemerkung - Note
 Für Trockenlauf geeignet!
 Use without coolant fluid allowed!

Technische Daten - technical data
 Weight = 5,412 [kg]
 Torque max. (M1/M2) = 32 / 32 [Nm]
 Speed max. (n1/n2) = 6000 / 6000 [1/min]
 Gear ratio (i)=n1:n2 = 1:1
 Pressure (pmax) = 70 [bar]

Benennung - Title
Radial Bohr und Fräskopf
Radial drilling and milling head



Nr. - No.
60.55.425LT2000V16IKDGLIM

Technische Änderungen vorbehalten!
 Subject to technical modifications!
 IDENT: DEWS121730

REV: -/D
 MNR.
154366

