

Spannzange / collet ER25 DIN6499
Spannbereich / clamping range: 1,0 - 16,0

Gewindebohrzange / tapping collet
ET-1-25 M3-M12

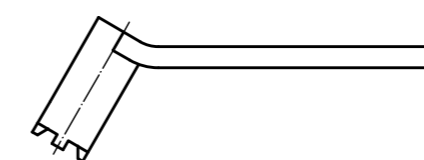

Schlüssel für Kontermutter
im Lieferumfang enthalten
Wrench for counternut
included in delivery
AZS-LT2000

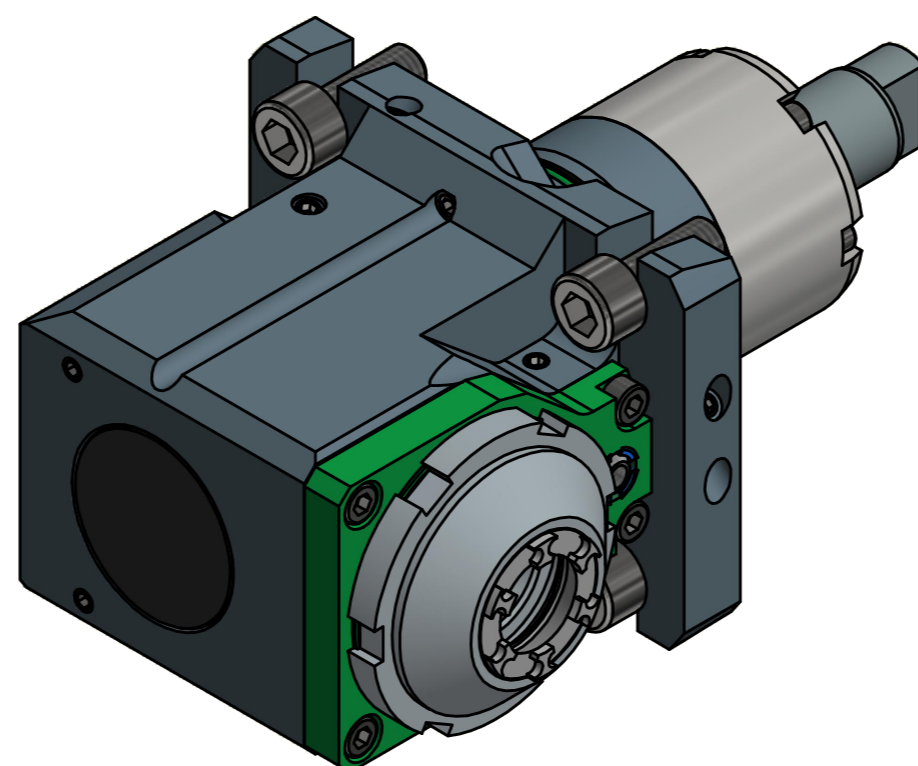
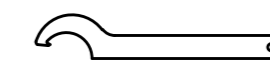

Hakenschlüssel
mit Nase
Hook wrench with
nose end
DIN1810 A 58x62

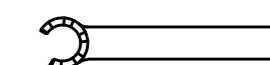

Spannzangenschlüssel für
innenliegende Mutter
Clamping wrench for
internal collet
225AX

Copyright **EWS Tool Technologies**
Weitergabe und Vervielfältigung dieser Unterlage,
Verwertung und Mitteilung ihres Inhalts nicht
gestattet, soweit nicht ausdrücklich zugestanden.
Zuwerhandlungen verpflichten zu Schadenersatz.

Bemerkung - Note

Technische Daten - technical data

Weight = 5,344 [kg]
Torque max. (M1/M2) = 32 / 32 [Nm]
Speed max. (n1/n2) = 6000 / 6000 [1/min]
Gear ratio (i)=n1:n2 = 1:1

Benennung - Title

Radial Bohr und Fräskopf
Radial drilling and milling head

EWS EWS Weigle GmbH & Co. KG
Maybachstr. 1
D-73066 Ulm/ingen
www.ews-tools.de

Technische Änderungen vorbehalten!
Subject to technical modifications!

IDENT: DEWS121404

REV: -/C

Nr. - No.
60.55.425LT2000V16GLIM

MNR.
154365

