

EWS.Varia

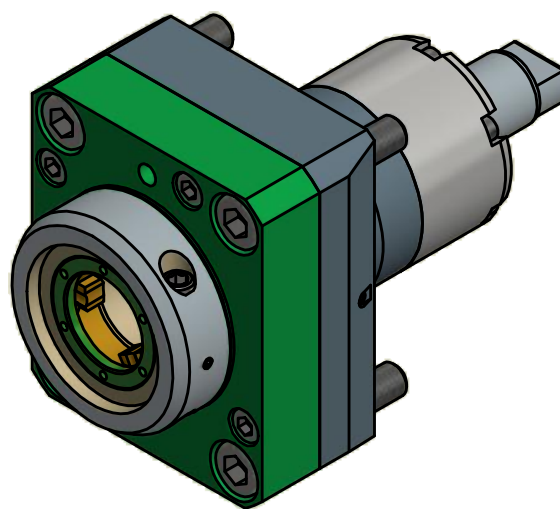

Tech
Details

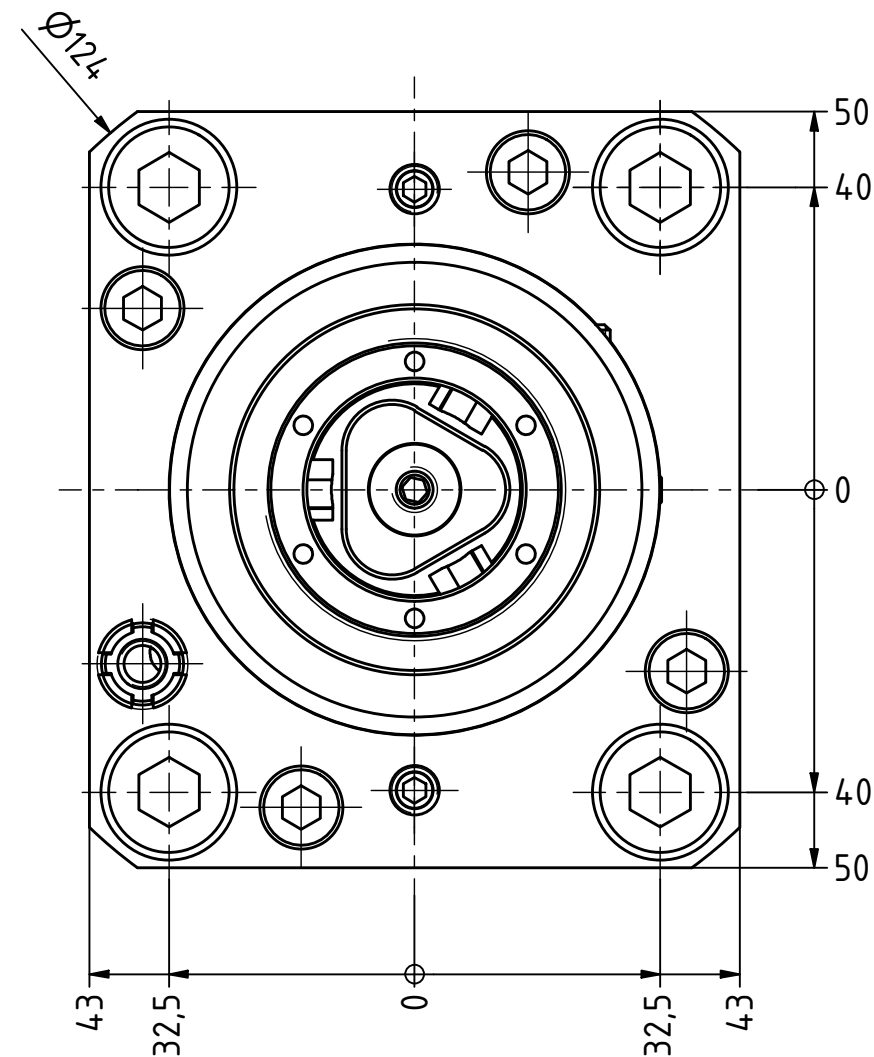
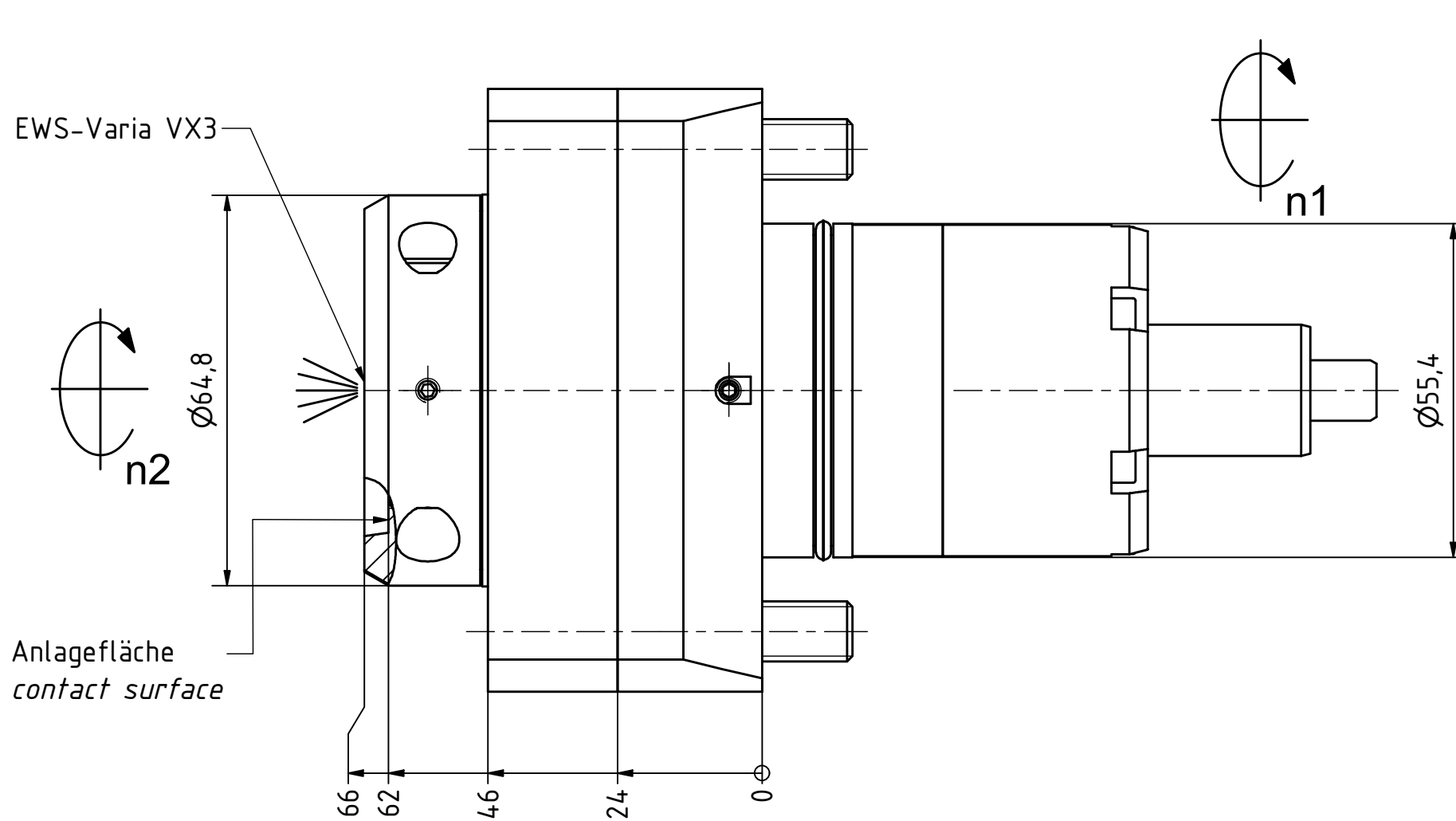

Copyright **EWS Tool Technologies**
 Weitergabe und Vervielfältigung dieser Unterlage,
 Verwertung und Mitteilung ihres Inhalts nicht
 gestattet, soweit nicht ausdrücklich zugestanden.
 Zuwiderhandlungen verpflichten zu Schadenersatz.

Bemerkung - Note

Technische Daten - technical data

Weight = 4.130 [kg]
 Torque max. (M1/M2) = 32 / 32 [Nm]
 Speed max. (n1/n2) = 6000 / 6000 [1/min]
 Gear ratio (i)=n1:n2 = 1:1

Benennung - Title

Axial Bohr und Fräskopf
 Axial drilling and milling head



Nr. - No.

40.55.4 VX3LT2000V16

Technische Änderungen vorbehalten!
 Subject to technical modifications!

IDENT: DEWS116704



REV: -/C

MNR.

154363

QR