

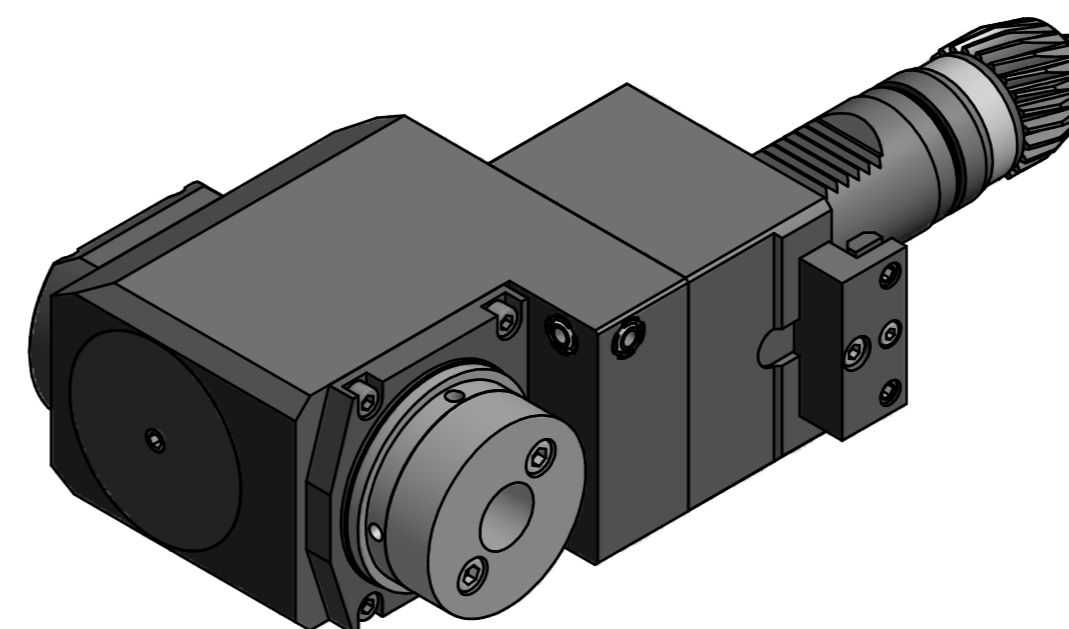



Hydrodehnfutter / hydraulic chuck NBC-20/25-46

Hülsen / collets 28.20xxHYDSP

XX (Ø) 3 4 5 6 7 8 9 10 12 14 16
 1/8 3/16 1/4 5/16 3/8 7/16 1/2 9/16 5/8

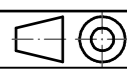

Copyright **EWS Tool Technologies**
 Weitergabe und Vervielfältigung dieser Unterlage,
 Verwertung und Mitteilung ihres Inhalts nicht
 gestattet, soweit nicht ausdrücklich zugestanden.
 Zuwiderhandlungen verpflichten zu Schadenersatz.

Bemerkung - Note	Technische Daten - technical data Weight = 9.504 [kg] Torque max. (M1/M2) = 45 / 15 [Nm] Speed max. (n1/n2) = 6000 / 18000 [1/min] Gear ratio (i)=n1:n2 = 1:3	Benennung - Title Radial Bohr und Fräskopf. zurückges Radial drill. and mill. head offset	 EWS Weigle GmbH & Co. KG Maybachstr. 1 D-73066 Uhringen www.ews-tools.de	Technische Änderungen vorbehalten! Subject to technical modifications! IDENT: D-EWS-096026 Nr. - No. 80.4020HYDMFT300R113	 REV: -/- MNR. 152024 
------------------	---	---	--	--	--