

6 | 5 | 4 | 3 | 2 | 1

D
C
B
A

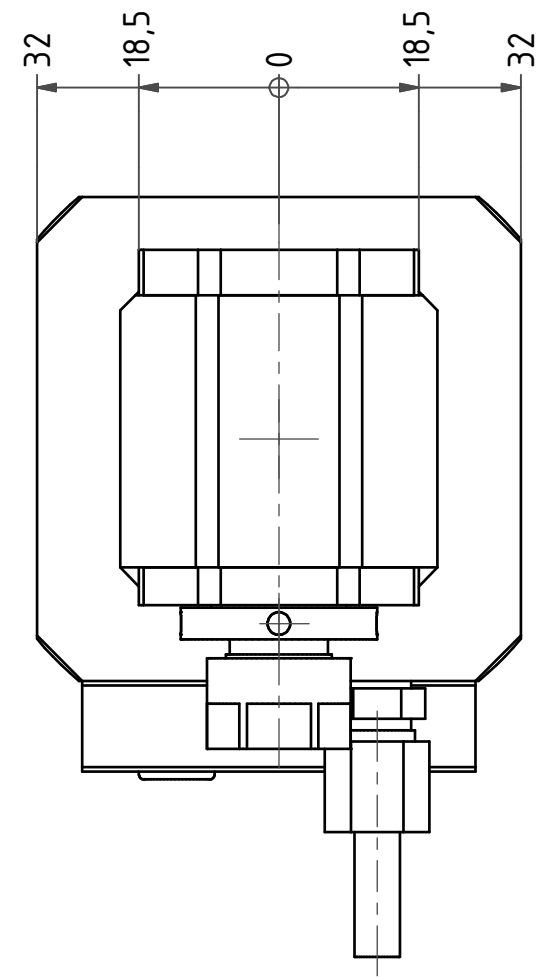
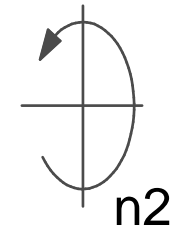
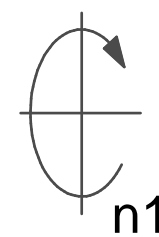
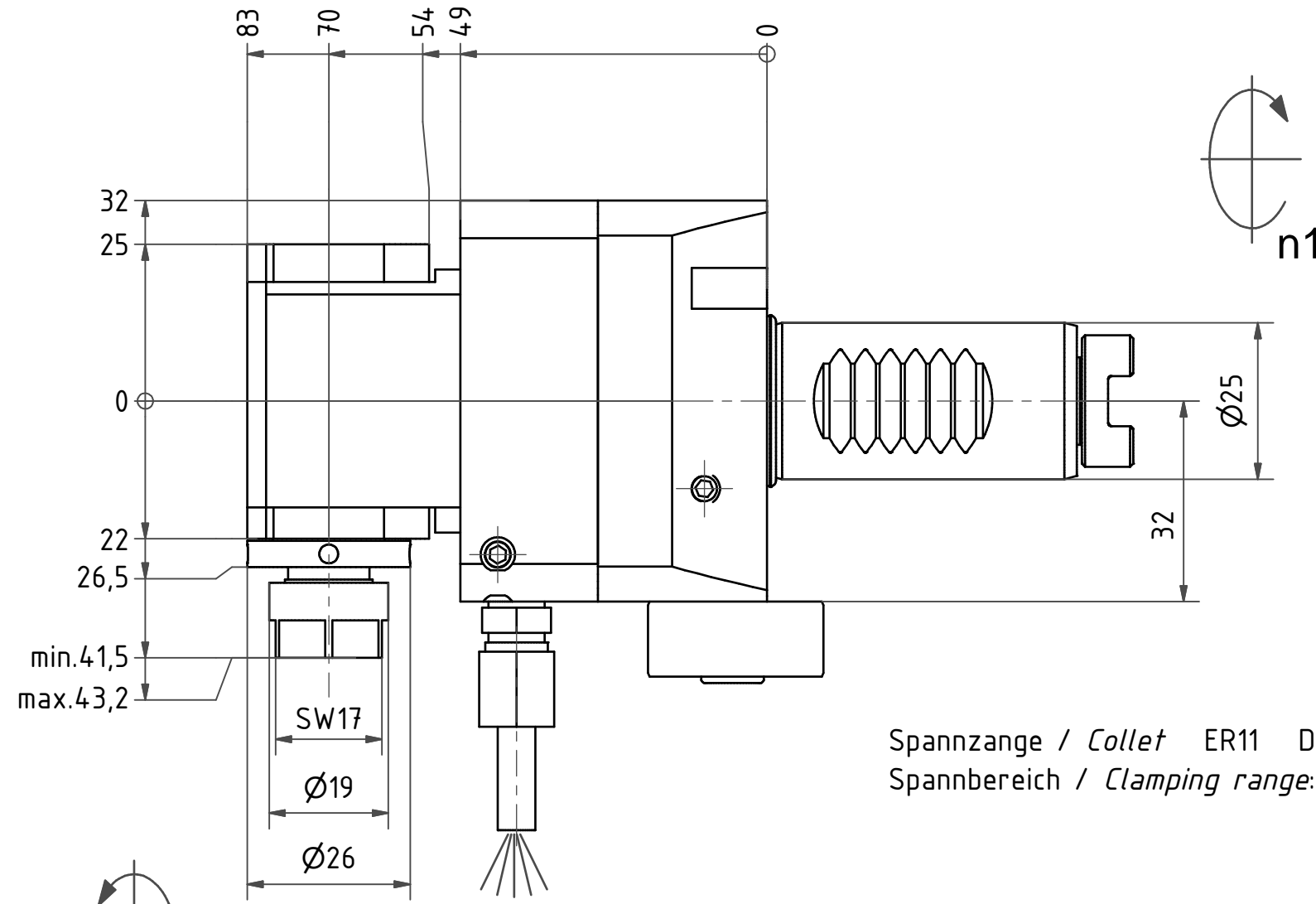

Spannzange / Collet ER11 DIN6499
Spannbereich / Clamping range: 0,5 - 7,0

Doppelverzahnung Lizenz Traub
double tooth system licence Traub

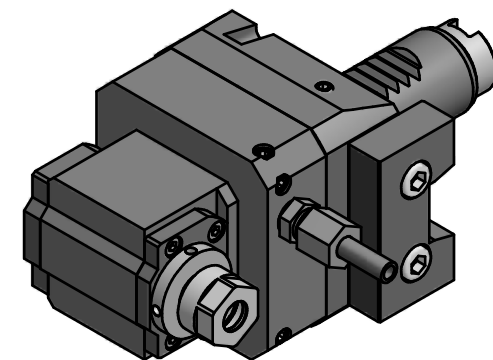
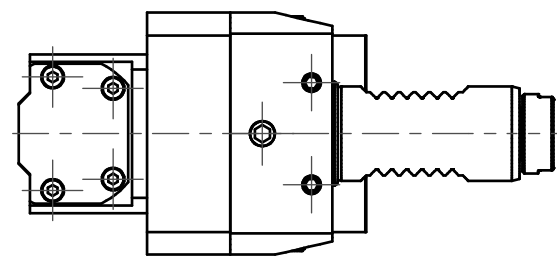

Hakenschlüssel
mit Zapfen
Hook wrench
with fixed pin
DIN1810 B 25x28

Copyright **EWS Tool Technologies**
Weitergabe und Vervielfältigung dieser Unterlage,
Verwertung und Mitteilung ihres Inhalts nicht
gestattet, soweit nicht ausdrücklich zugestanden.
Zuwendungen verpflichten zu Schadenersatz.

| | | | | | | | | |
|-------------------------|---|--|--|------|------|-------------|------------|---|
| <p>Bemerkung - Note</p> | <p>Technische Daten - technical data M1 / M2 = 6,3 / 6,3 Nm n1 / n2 = 8000 / 8000 1/min i (N1:N2) = 1:1</p> | <p>Benennung - Title Radial Bohr und Fräskopf Radial drilling and milling head</p> | <table border="1"> <tr> <td>name</td> <td>date</td> </tr> <tr> <td>Kratschmann</td> <td>21.06.2010</td> </tr> </table> <p>EWS EWS Weigete GmbH & Co. KG Maybachstr. 1 D-73066 Uhingen Tel. +49(0)7161/93040-100</p> | name | date | Kratschmann | 21.06.2010 | <p>Technische Aenderungen vorbehalten! Subject to technical modifications!</p> <p>Nr. 60.2512G200RLV</p> <p>MNR: 122208 IDENT: D-EWS-090394 B Blatt - page 1 (1)</p> |
| name | date | | | | | | | |
| Kratschmann | 21.06.2010 | | | | | | | |

6 | 5 | 4 | 3 | 2 | 1