

Clamping torque: 50 Nm

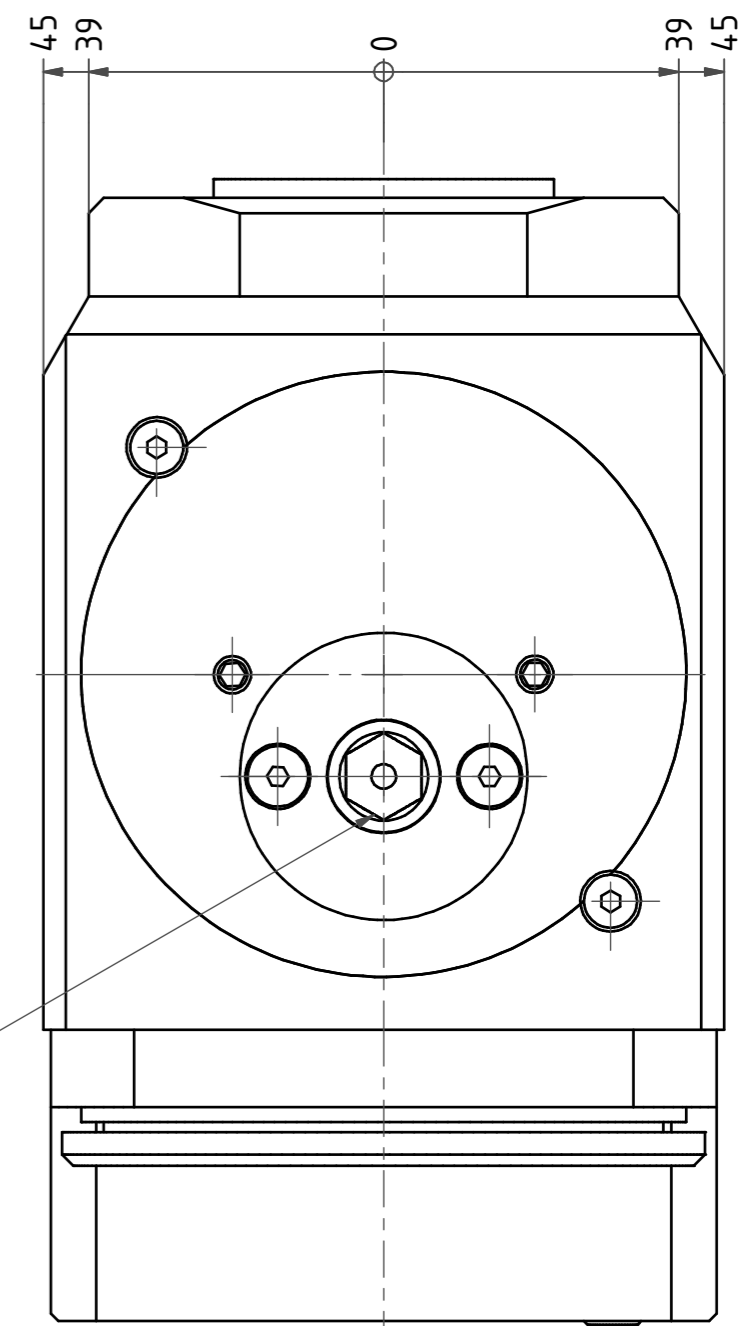

Capto C4-Aufnahme  
Capto C4-Adaptor

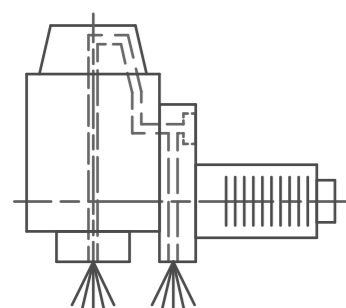
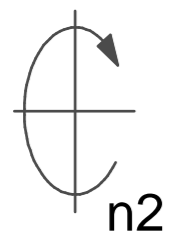

Innen- und Aussenkuehlung / Inside and outside coolant supply  
Kein Trockenlauf / No dry run  
Kuehlmittelfiltrierung 50µ / coolant filtration 50µ

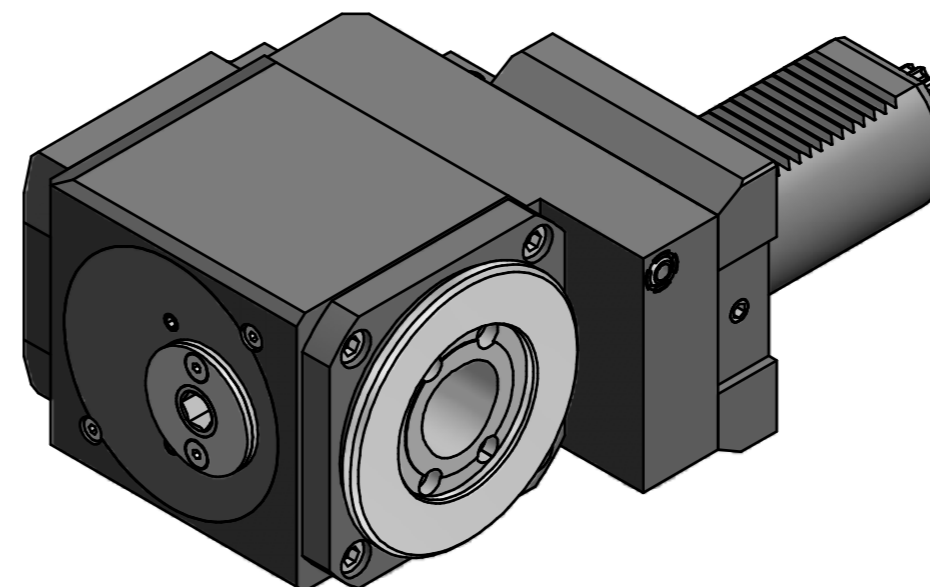

Bemerkung - Note  
Nicht ohne Kuehlmittel betreiben!  
Not for use without coolant-fluid!

Technische Daten - Technical data  
M1 / M2 = 50 / 50 Nm  
n1 / n2 = 4000 / 4000 1/min  
i (N1:N2) = 1:1  
Pmax = 70 bar

Benennung - Title  
Radial Bohr und Fräskopf. zurückges  
Radial drill. and mill. head offset

drawing	name	date
Kratschmann		15.02.2007

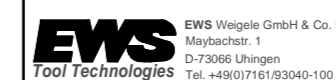

Technische Aenderungen vorbehalten!  
Subject to technical modifications!

Nr. **80.50C45482RIK-BG40**

MNR: 121267 IDENT: D-EWS-002670 - Blatt - page 1 (1)



DIN A2