

Spannzange / collet ER40 DIN6499
 Spannbereich / clamping range: 3,0 - 26,0

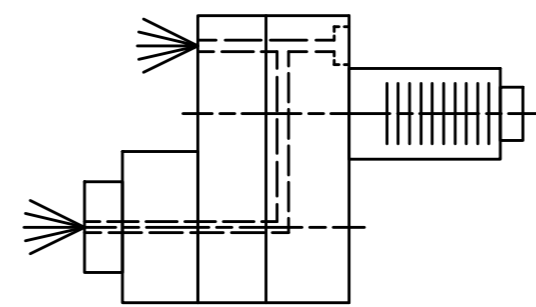

Innen- und Aussenkuehlung
 Inside and outside coolant supply

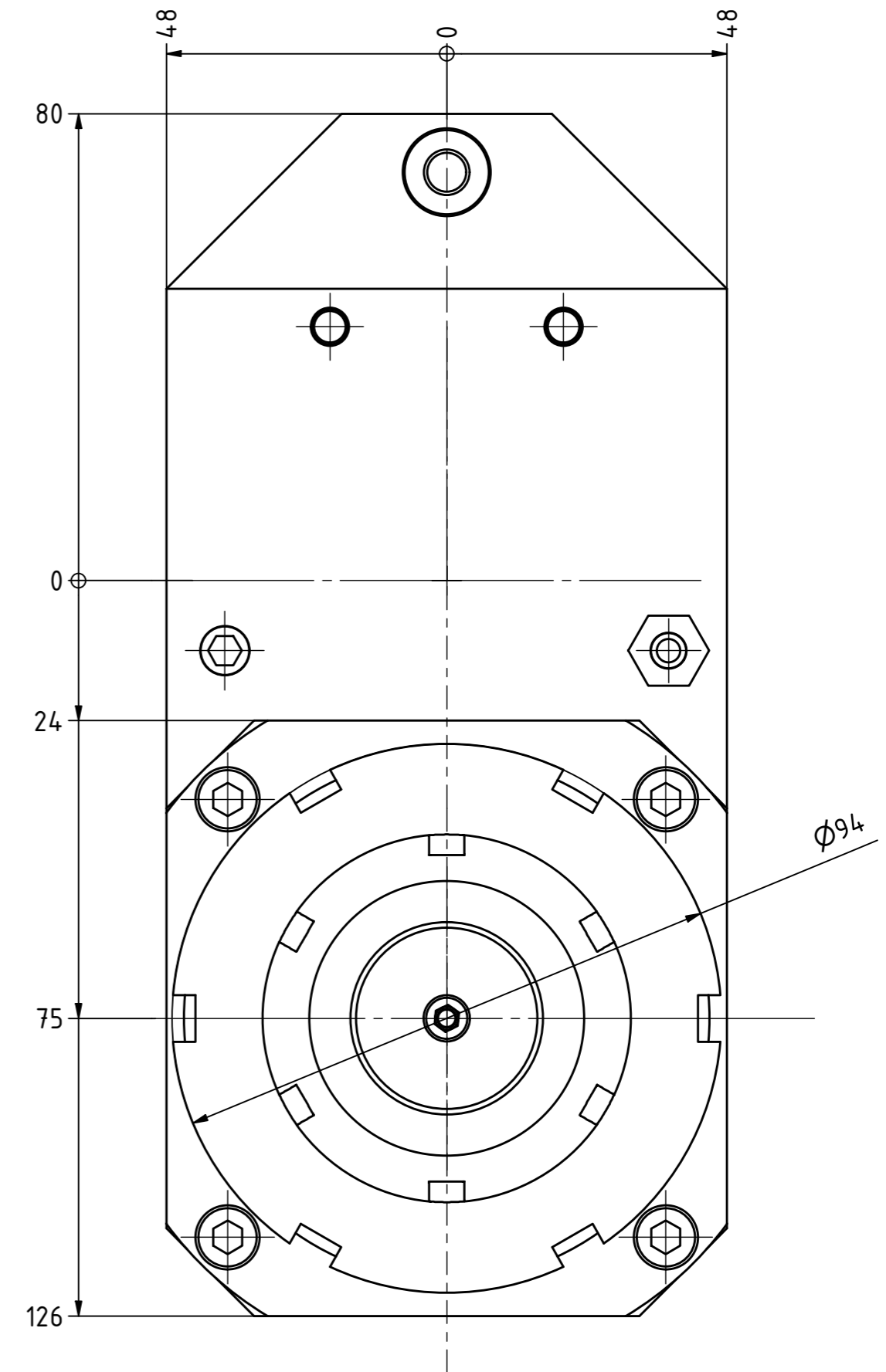
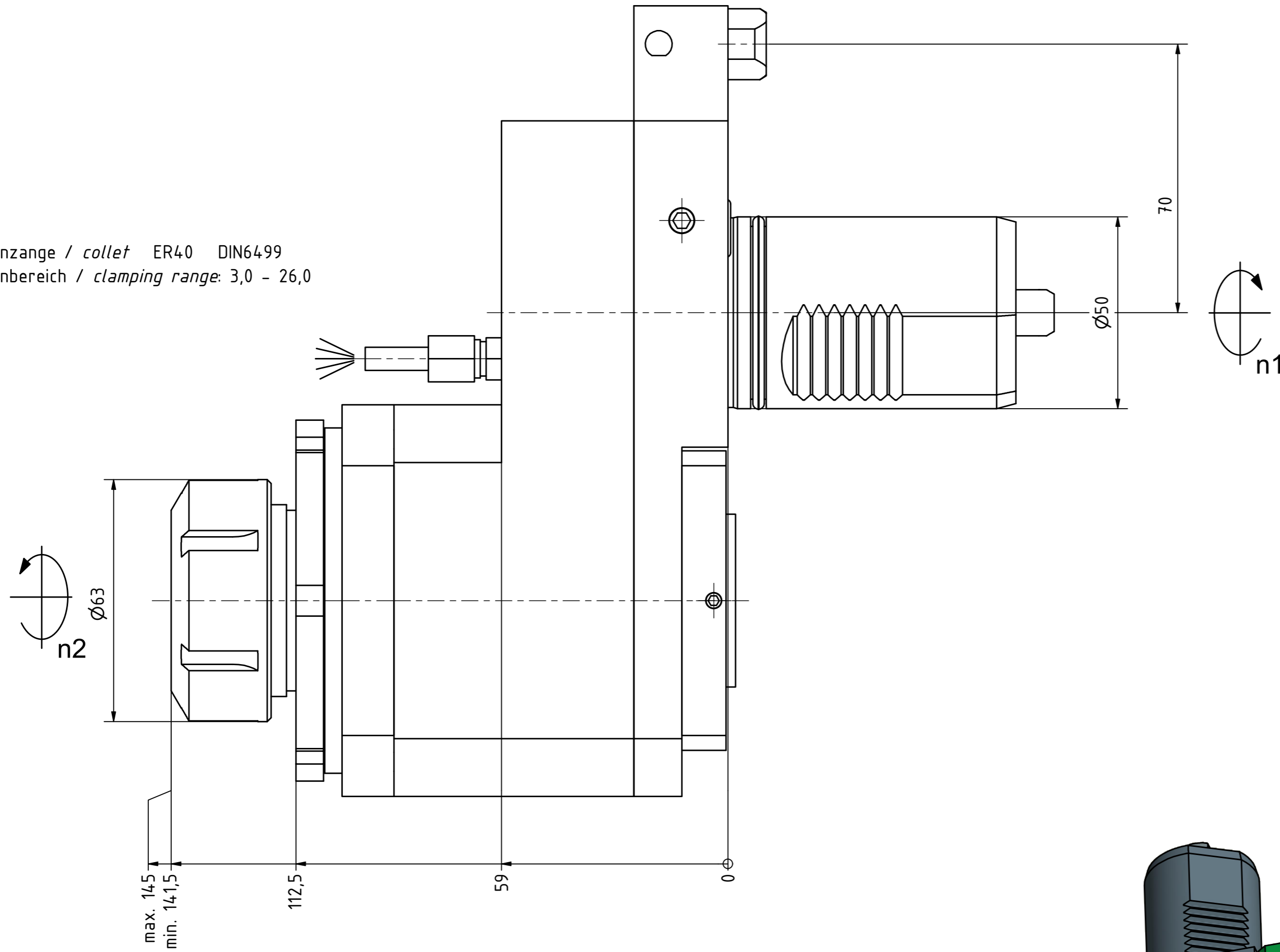
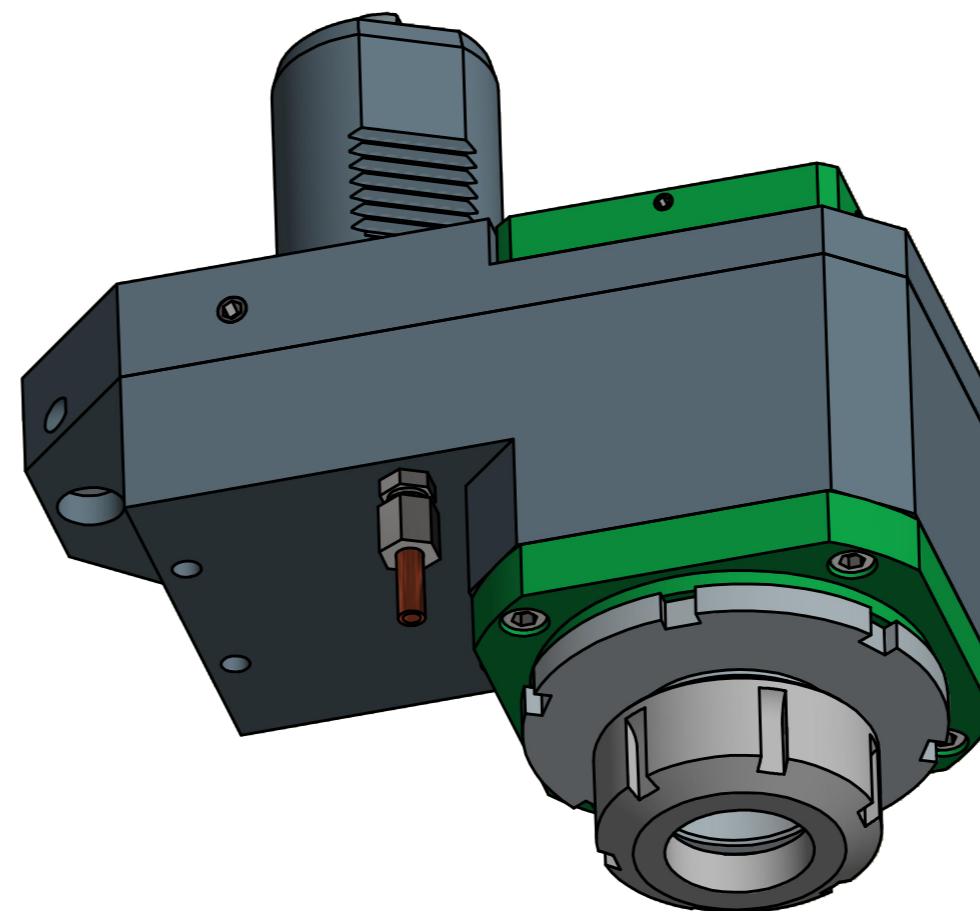
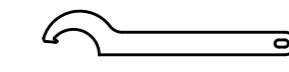

 Hakenschlüssel
 mit Nase
 Hook wrench with
 nose end
 DIN1810 A 95x100

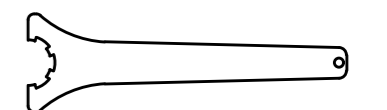
 Spannzangenschlüssel
 Clamping wrench
 240

Copyright **EWS Tool Technologies**
 Weitergabe und Vervielfaeltigung dieser Unterlage,
 Verwertung und Mitteilung ihres Inhalts nicht
 gestattet, soweit nicht ausdrecklich zugestanden.
 Zuwiderhandlungen verpflichten zu Schadenersatz.

Bemerkung - Note
 Nicht ohne Kuehlmittel betreiben!
 Not for use without coolant-fluid!

Technische Daten - technical data
 Weight = 11,466 [kg]
 Torque max. (M1/M2) = 100 / 100 [Nm]
 Speed max. (n1/n2) = 6000 / 6000 [1/min]
 Gear ratio (i)=n1:n2 = 1:1
 Pressure (pmax) = 70 [bar]

Benennung - Title
Axial Bohr u. Fräskopf achsversetzt
Ax. drill. and mill. head offset

EWS Tool Technologies
 EWS Weigle GmbH & Co. KG
 Maybachstr. 1
 D-73066 Uhlingen
 www.ews-tool.de
 Nr. - No.
50.5040SQT28RIK

Technische Aenderungen vorbehalten!
 Subject to technical modifications!
 IDENT: DEWS123049
 REV: -/A

MNR.
119972

