

Spannzange / collet ER40 DIN6499
 Spannbereich / clamping range: 3,0 - 26,0

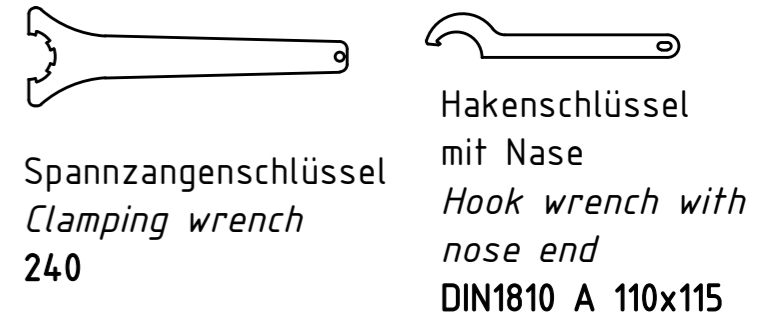

Spannzangenschlüssel
 Clamping wrench
 24,0

Hakenschlüssel
 mit Nase
 Hook wrench with
 nose end
 DIN1810 A 110x115

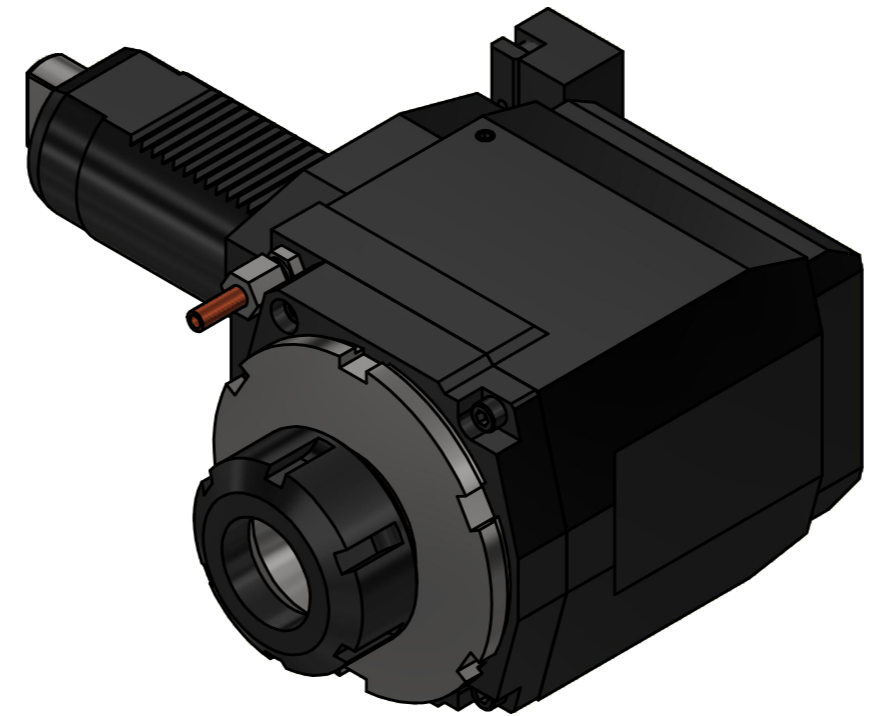
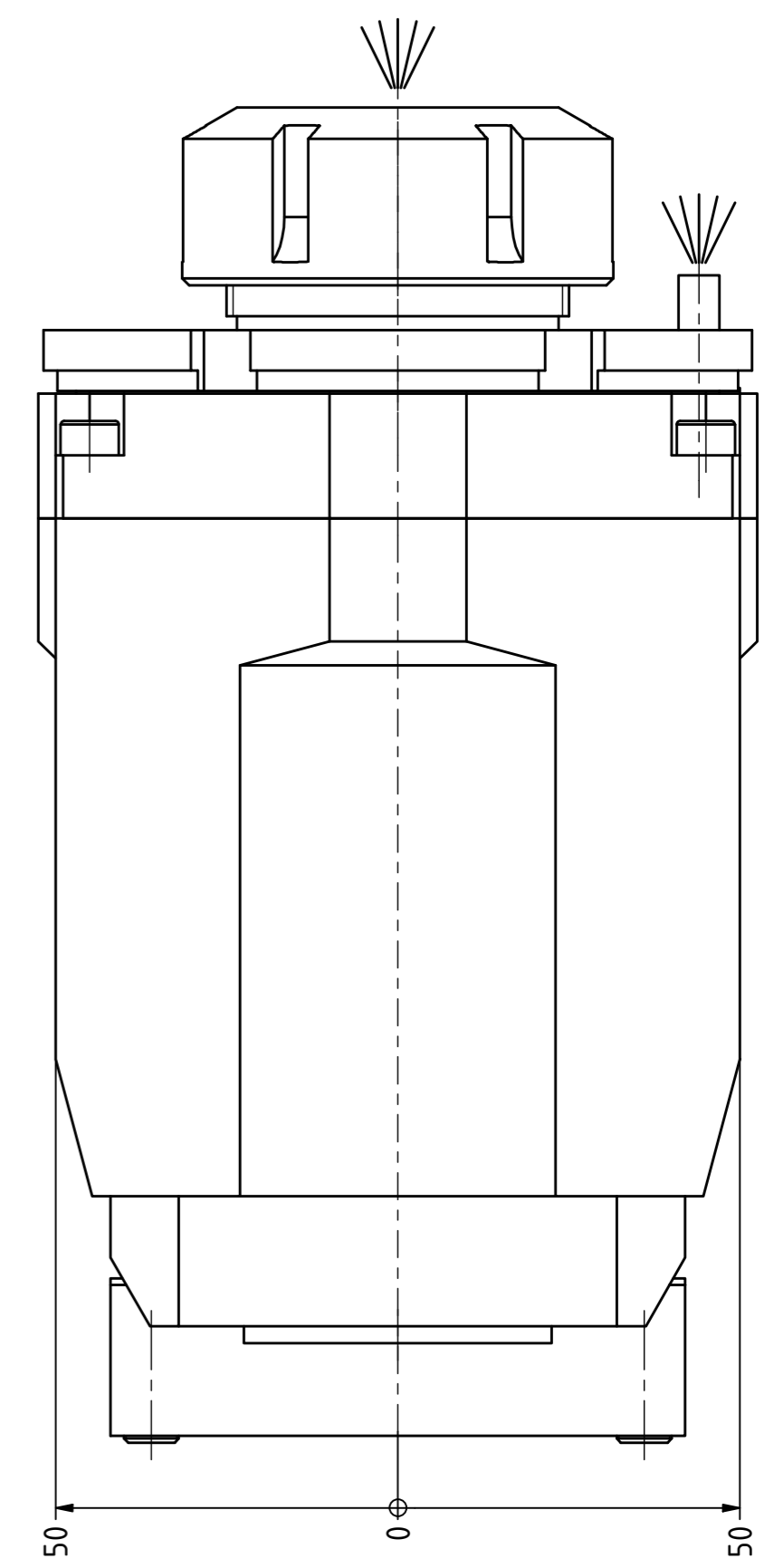
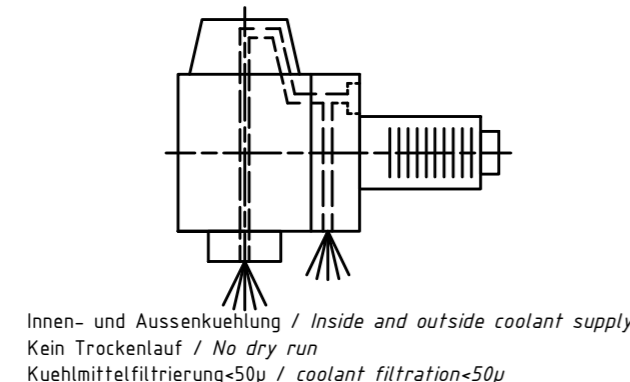

Innen- und Aussenkuehlung / Inside and outside coolant supply
 Kein Trockenlauf / No dry run
 Kuehlmittelfiltrierung=50µ / coolant filtration=50µ

Bemerkung - Note	Technische Daten - technical data
Nicht ohne Kuehlmittel betreiben! Not for use without coolant-fluid!	Weight = 12.249 [kg]
mit Kegelrollenlager with taper roller bearing(s)	Torque max. (M1/M2) = 80 / 160 [Nm]
	Speed max. (n1/n2) = 4000 / 2000 [1/min]
	Gear ratio (i)=n1:n2 = 2:1
	Pressure (pmax) = 70 [bar]

Benennung - Title
Radial Bohr und Fräskopf
Radial drilling and milling head

	<small>EWS Weigle GmbH & Co. KG Maybachstr. 1 D-73066 Uhlingen www.ews-tools.de</small>	<small>Technische Aenderungen vorbehalten! Subject to technical modifications!</small>	
		<small>IDENT: DEWS149238</small>	
<small>Nr. - No.</small> 60.5040KRVL5LIK12	<small>MNR.</small> 155037	QR	

Copyright **EWS Tool Technologies**
 Weitergabe und Vervielfaeltigung dieser Unterlage,
 Verwertung und Mitteilung ihres Inhalts nicht
 gestattet, soweit nicht ausdrecklich zugestanden.
 Zuwiderhandlungen verpflichten zu Schadenersatz.