

EWS-Varia V5

Doppelverzahnung Lizenz Traub
double tooth system licence Traub

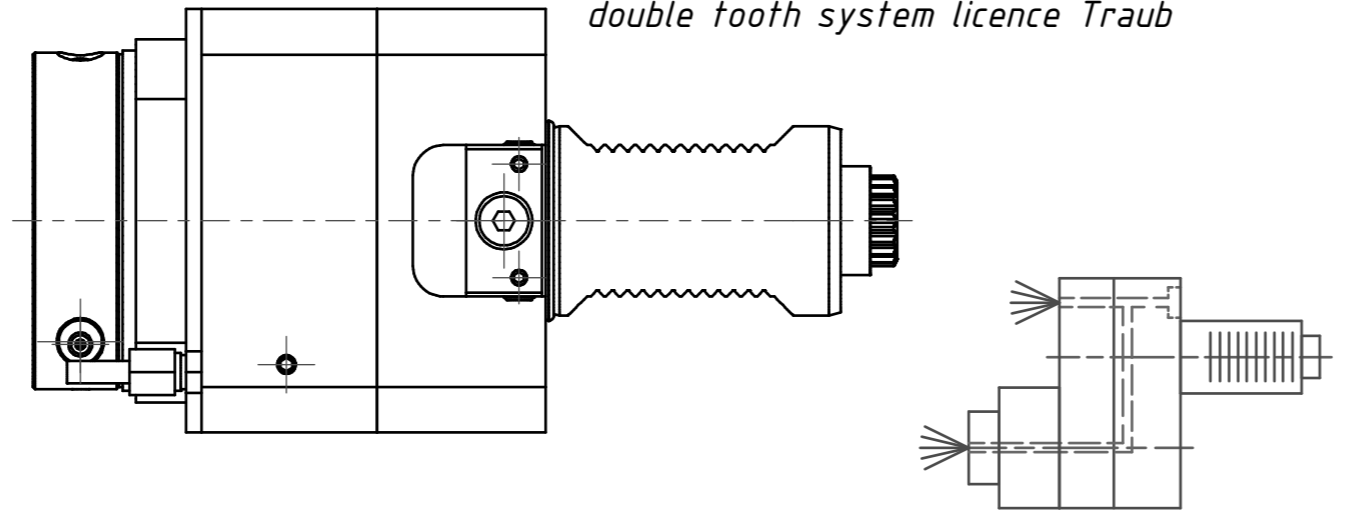

Innen- und Aussenkuehlung / *Inside and outside coolant supply*
 Kein Trockenlauf / *No dry run*
 Kuehmittelfiltrierung <math>< 50\mu</math> / *coolant filtration <math>< 50\mu</math>*

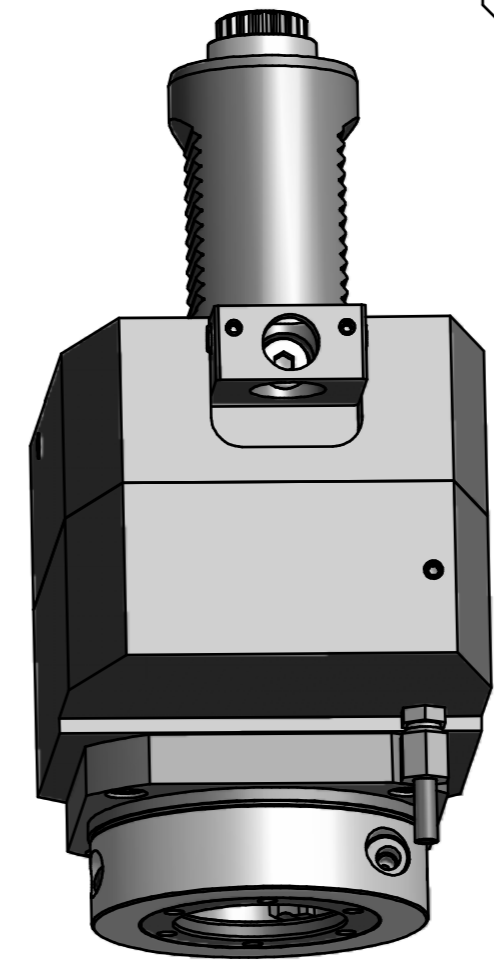

Copyright **EWS Tool Technologies**
 Weitergabe und Vervielfaeltigung dieser Unterlage,
 Verwertung und Mitteilung ihres Inhalts nicht
 gestattet, soweit nicht ausdrecklich zugestanden.
 Zuwiderhandlungen verpflichten zu Schadenersatz.

Bemerkung - <i>Note</i> Nicht ohne Kuehlmittel betreiben! <i>Not for use without coolant-fluid!</i> Schutzrecht angemeldet Trademark right applied	Technische Daten - <i>technical data</i> M1 / M2 = 100 / 50 Nm n1 / n2 = 4000 / 8000 1/min i (N1:N2) = 1:2 Pmax = 70 bar	Benennung - <i>Title</i> Axial Bohr u. Fräskopf achsversetzt <i>Ax. drill. and mill. head offset</i>	name Schmid	date 10.03.2010	Technische Aenderungen vorbehalten! <i>Subject to technical modifications!</i> Nr. 50.50V554.80RLIK11 MNR: 153219 IDENT: D-EWS-086360 - Blatt - page 1 (1)
			EWS Wiegels GmbH & Co. KG Maybachstr. 1 D-72066 Ehingen Tel. +49(0)716193040-100		