

Polygon ISO 26623
PSC 40

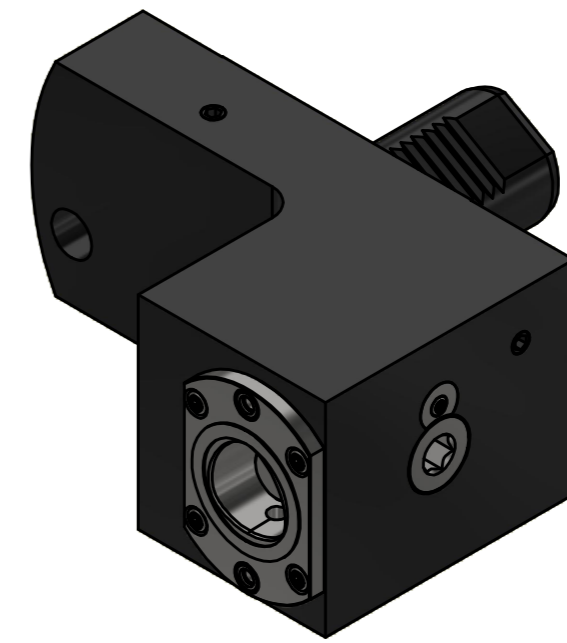

Copyright **EWS Tool Technologies**
Weitergabe und Vervielfältigung dieser Unterlage,
Verwertung und Mitteilung ihres Inhalts nicht
gestattet, soweit nicht ausdrücklich zugestanden.
Zuwerhandlungen verpflichten zu Schadenersatz.

<p>Bemerkung - Note</p> <p>MA = 50 Nm max. 80 bar</p>	<p>Technische Daten - technical data</p> <p>Weight = 6.191 [kg]</p>	<p>Benennung - Title</p> <p>Längsaufnahme <i>turning holder lengthwise</i></p>	<p>EWS Tool Technologies EWS Weigle GmbH & Co. KG Maybachstr. 1 D-73066 Uhingen www.ews-tool.de</p>	<p>Technische Änderungen vorbehalten! Subject to technical modifications!</p> <p>IDENT: DEWS237119</p>	<p>REV: -/B</p> <p>MNR.</p> <p>121164</p>	<p>QR</p>
---	---	---	--	--	---	-----------