

Clamping torque: 70Nm

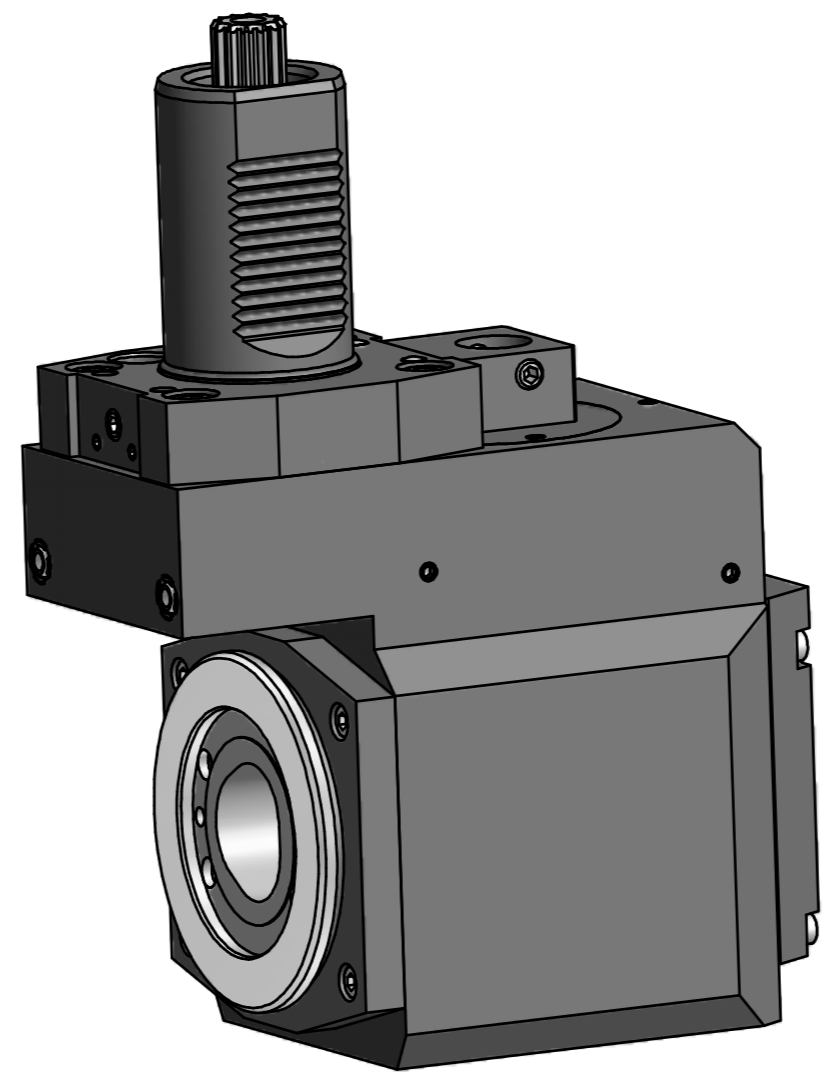
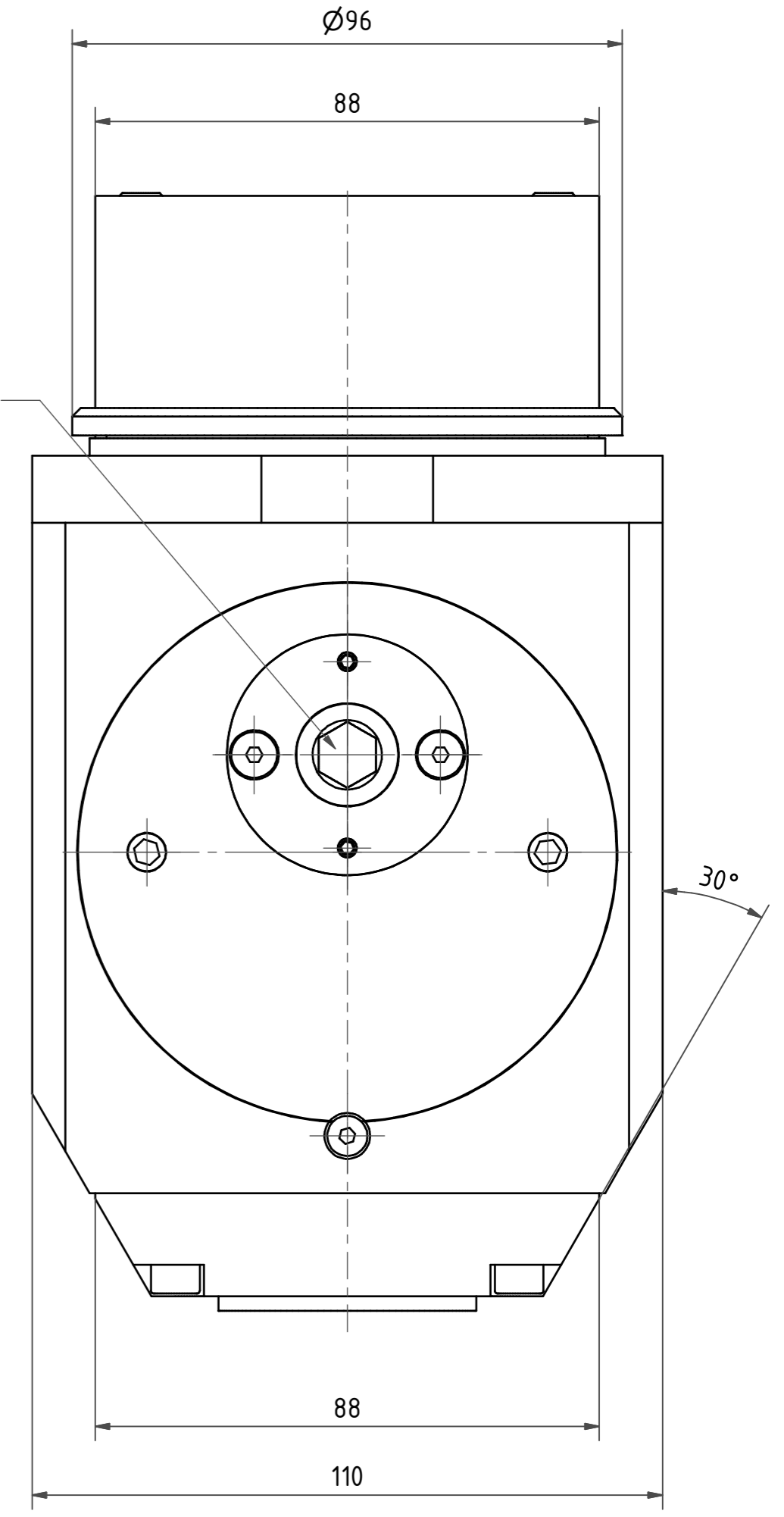
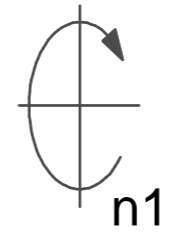

Copyright **EWS Tool Technologies**
 Weitergabe und Vervielfältigung dieser Unterlage,
 Verwertung und Mitteilung ihres Inhalts nicht
 gestattet, soweit nicht ausdrücklich zugestanden.
 Zuwiderhandlungen verpflichten zu Schadenersatz.

Bemerkung - Note	Technische Daten - Technical data		Benennung - Title	name date Technische Änderungen vorbehalten! Subject to technical modifications! Nr. 80.50C55482L MNR: 153137 IDENT: D-EWS-098848 - Blatt - page 1 (1)
	M ₁ / M ₂ = 100 / 100 Nm n ₁ / n ₂ = 4000 / 4000 1/min i (N1:N2) = 1:1			
drawing Kraftschmann 01.02.2011 EWS EWS Weigste GmbH & Co. KG Maybachstr. 1 D-73066 Ulm/lingen Tel. +49(0)7161/93040-100 Tool Technologies				DIN A2