

Whistle Notch / Weldon
M16 (2x)

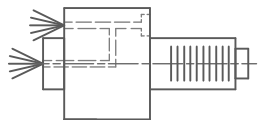

Innen- und Aussenkuehlung / Inside and outside coolant supply
Kuehlmittelfiltrierung*50µ / coolant filtration*50µ

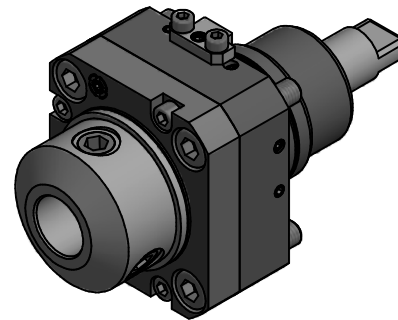

Copyright **EWS Tool Technologies**
Weitergabe und Vervielfaeltigung dieser Unterlage,
Verwertung und Mitteilung ihres Inhalts nicht
gestattet, soweit nicht ausdruercklich zugestanden.
Zuwiderhandlungen verpflichten zu Schadenersatz.

<p>Bemerkung - Note</p> <p>Für Trockenlauf geeignet! Use without coolant fluid allowed!</p> <p>mit Kegelrollenlager with taper roller bearing(s)</p>	<p>Technische Daten - technical data</p> <p>Weight = 3.640 [kg]</p> <p>Torque max. (M1/M2) = 50 / 50 [Nm]</p> <p>Speed max. (n1/n2) = 5000 / 5000 [1/min]</p> <p>Gear ratio (i)=n1:n2 = 1:1</p> <p>Pressure (pmax) = 70 [bar]</p>	<p>Benennung - Title</p> <p>Axial Bohr und Fräskopf Axial drilling and milling head</p>	<p>EWS Tool Technologies</p> <p><small>EWS Weigelt GmbH & Co. KG Maybachstr. 1 D-73066 Uhingen www.ews-tools.de</small></p>	<p>Technische Aenderungen vorbehalten! Subject to technical modifications!</p> <p>IDENT: DEWS022664</p>	<p>REV: -/A</p> <p>MNR.</p> <p>153982</p>	<p>QR</p>
--------------------------------------------------------------------------------------------------------------------------------------------------------------	-----------------------------------------------------------------------------------------------------------------------------------------------------------------------------------------------------------------------------------	-----------------------------------------------------------------------------------------------------------	--------------------------------------------------------------------------------------------------------------------------------------------------------	-------------------------------------------------------------------------------------------------------------	--------------------------------------------------	-----------