

Spannzange / collet ER32 DIN6499  
 Spannbereich / clamping range: 2,0 - 20,0

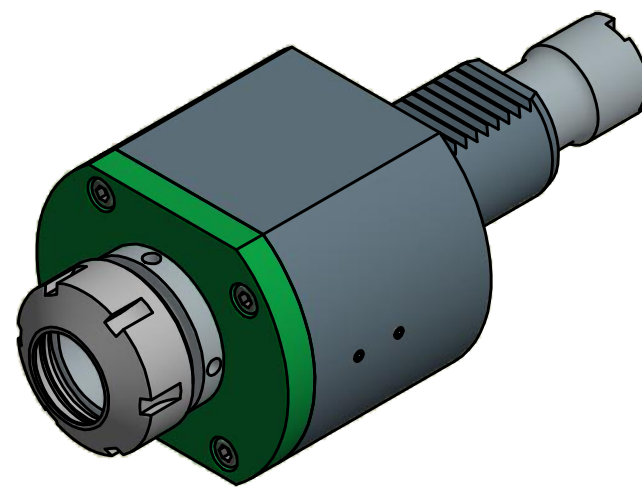

  
 Hakenschlüssel  
 mit Zapfen  
 Hook wrench  
 with fixed pin  
 DIN1810 B 45x50

  
 Spannzangenschlüssel  
 Clamping wrench  
 232

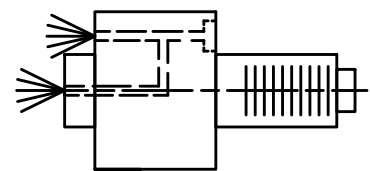

Innen- und Aussenkuehlung / Inside and outside coolant supply  
 Kein Trockenlauf / No dry run  
 Kuehlmittelfiltrierung <math>< 50\mu</math> / coolant filtration <math>< 50\mu</math>

Copyright **EWS Tool Technologies**  
 Weitergabe und Vervielfaeltigung dieser Unterlage,  
 Verwertung und Mitteilung ihres Inhalts nicht  
 gestattet, soweit nicht ausdrecklich zugestanden.  
 Zuwiderhandlungen verpflichten zu Schadenersatz.

<p>Bemerkung - Note          Nicht ohne Kuehlmittel betreiben!          Not for use without coolant-fluid!</p>	<p>Technische Daten - technical data          Weight = 4.090 [kg]          Torque max. (M1/M2) = 50 / 50 [Nm]          Speed max. (n1/n2) = 6000 / 6000 [1/min]          Gear ratio (i)=n1:n2 = 1:1          Pressure (pmax) = 25 [bar]</p>	<p>Benennung - Title          Axial Bohr und Fräskopf          Axial drilling and milling head</p>	<p><b>EWS</b> Tool Technologies          EWS Weigele GmbH &amp; Co. KG          Maybachstr. 1          D-73066 UHINGEN          www.ews-tools.de</p>	<p>Technische Aenderungen vorbehalten!          Subject to technical modifications!          IDENT: DEWS049979</p>	<p>          REV: -/A          MNR.          151636</p>	<p><b>QR</b></p>
--	---	--	--	--	--	------------------