

Spannzange / collet ER32 DIN6499
 Spannbereich / clamping range: 2,0 - 20,0

Gewindebohrzange / tapping collet
 ET-1-32 M5-M12

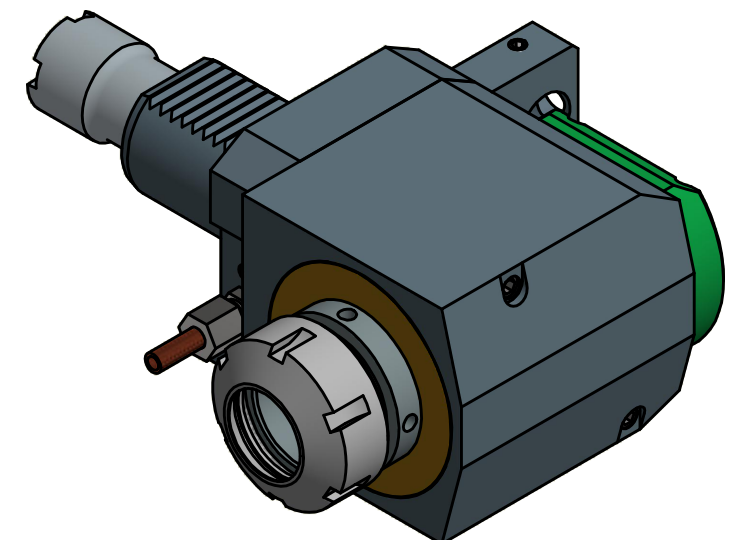

Copyright **EWS Tool Technologies**
 Weitergabe und Vervielfaeltigung dieser Unterlage,
 Verwertung und Mitteilung ihres Inhalts nicht
 gestattet, soweit nicht ausdrecklich zugestanden.
 Zuwiderhandlungen verpflichten zu Schadenersatz.

Bemerkung - Note Technische Daten - technical data Weight = 5.336 [kg] Torque max. (M1/M2) = [Nm] Speed max. (n1/n2) = [1/min] Gear ratio (i)=n1:n2 =	Benennung - Title Radial Bohr und Fräskopf <i>Radial drilling and milling head</i>	 EWS Weigle GmbH & Co. KG Maybachstr. 1 D-73066 Uhingen www.ews-tools.de Technische Aenderungen vorbehalten! Subject to technical modifications! IDENT: D-EWS-011468 Nr. - No. 60.4032LB15L	 REV: -/- MNR. 122756	
--	---	---	--	---