

Fraeserwelle austauschbar
Spindle removable

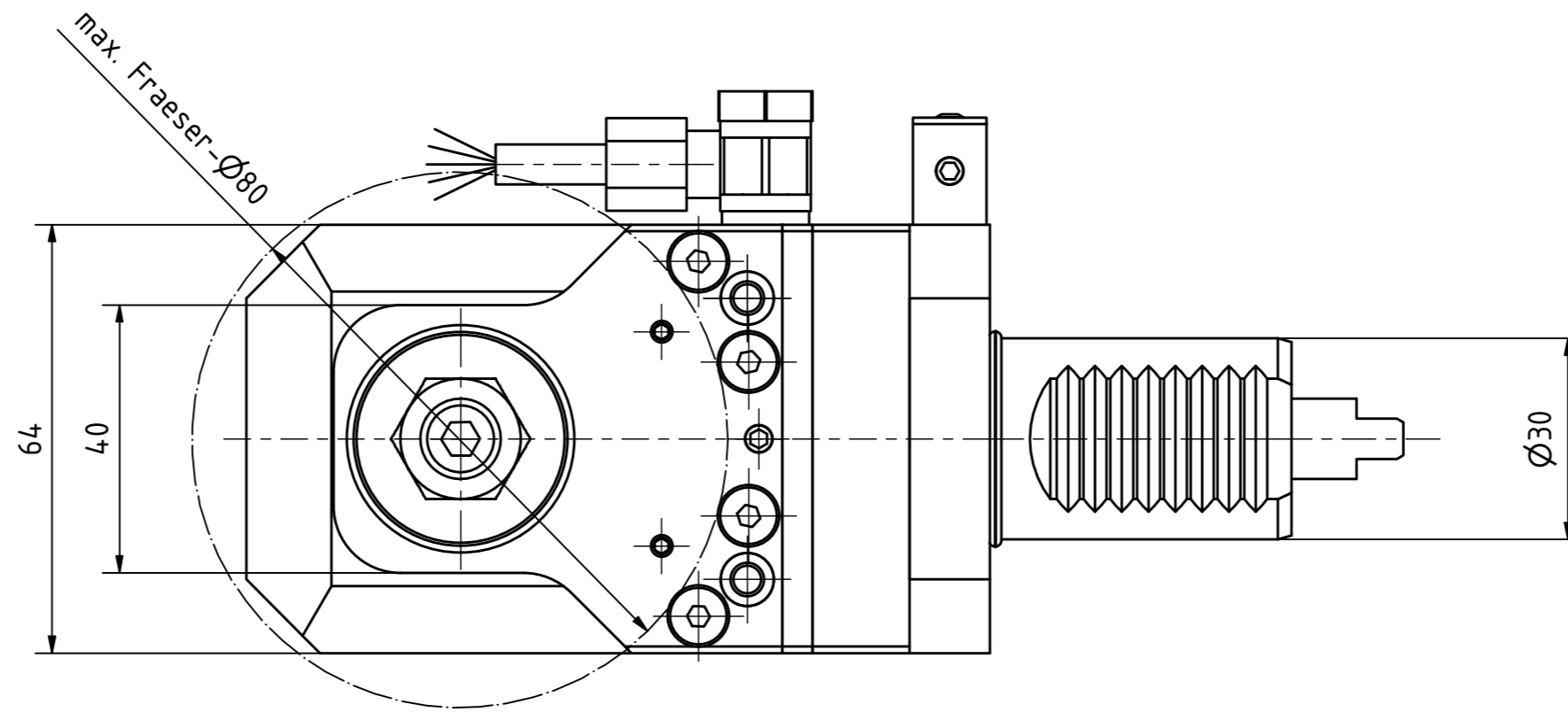
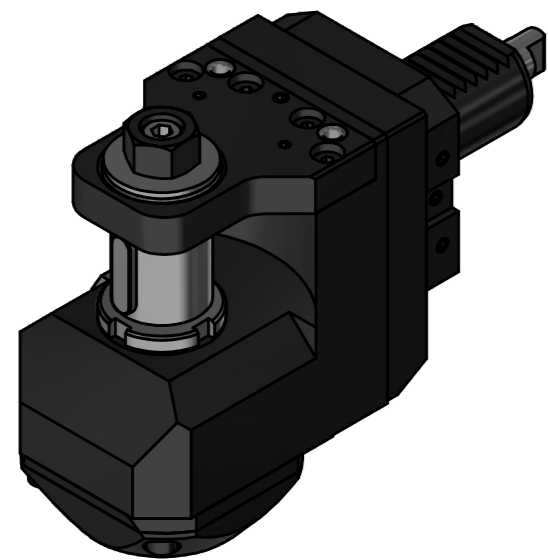
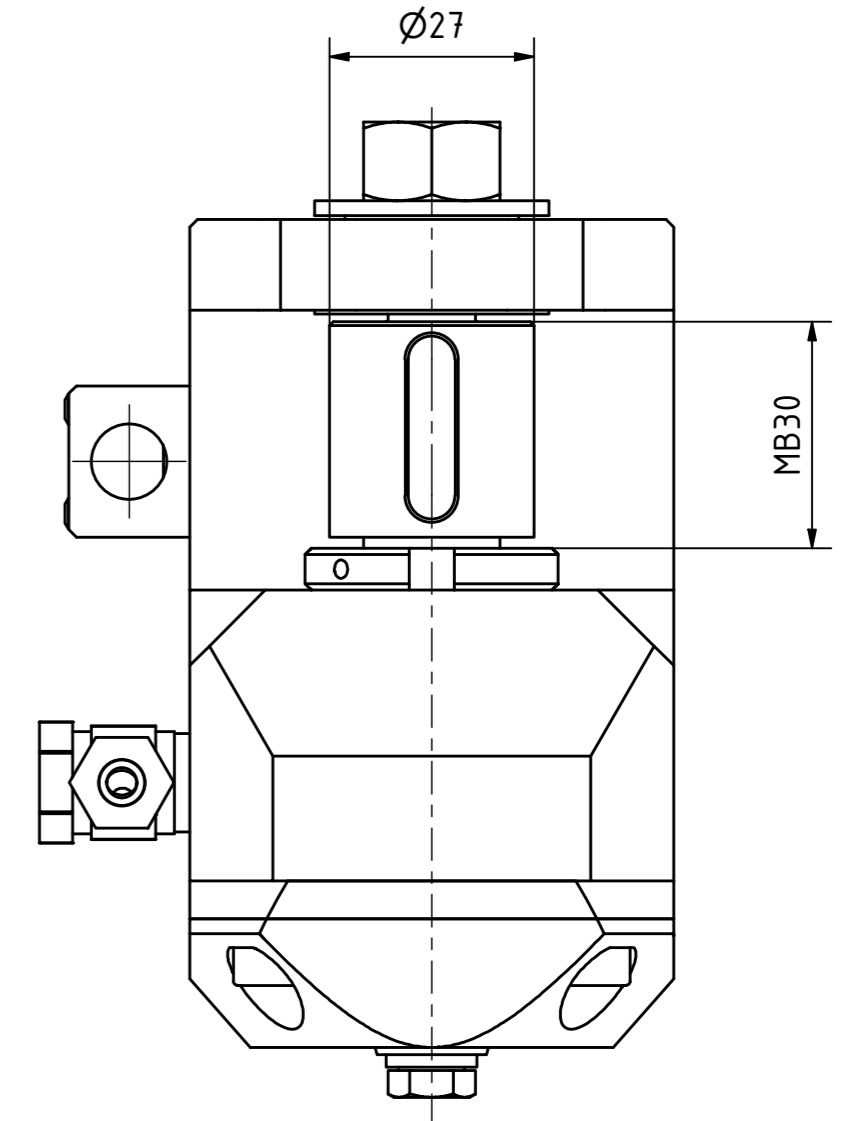
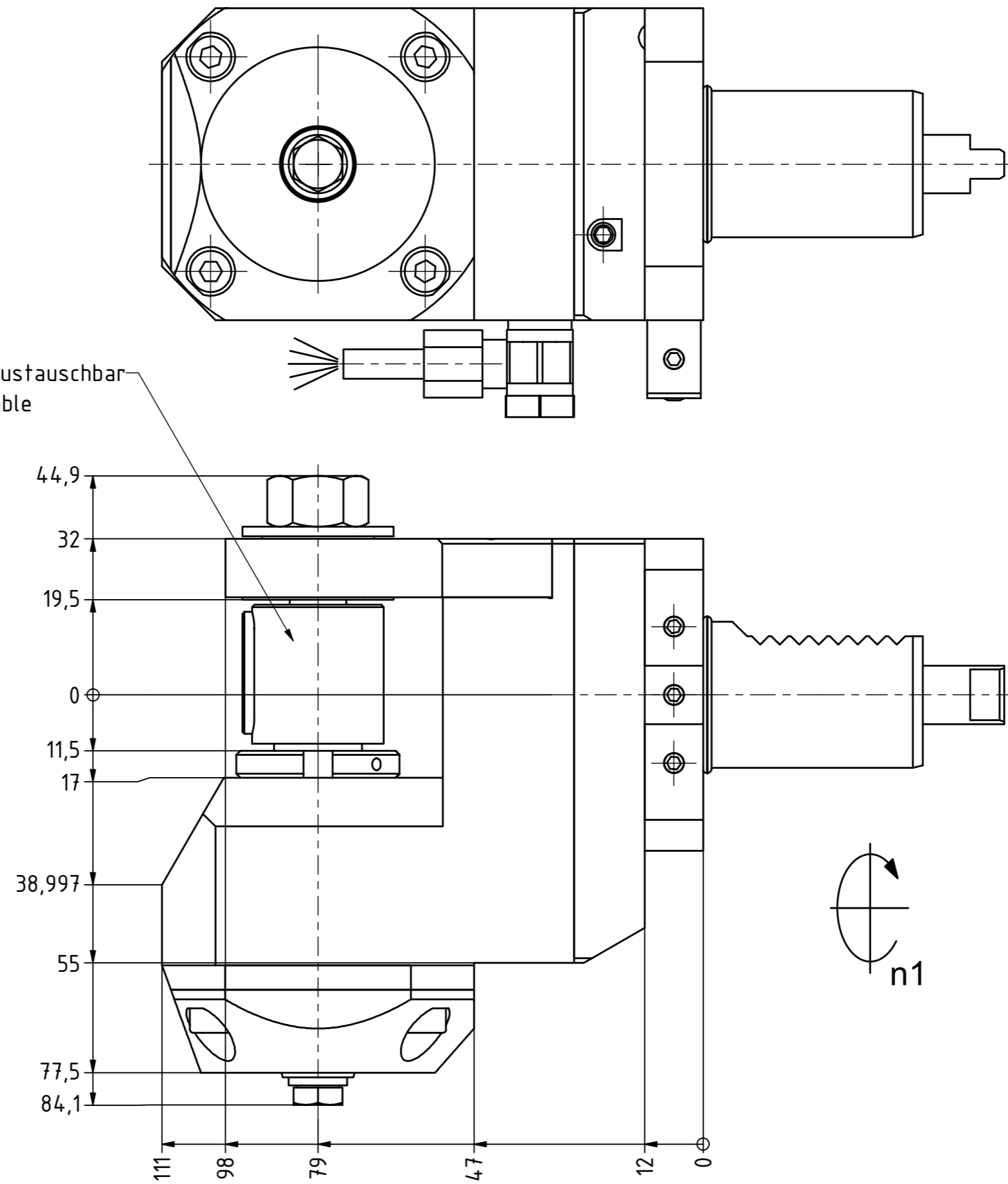
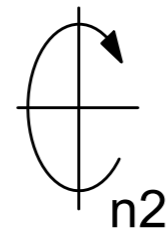

Copyright **EWS Tool Technologies**
Weitergabe und Vervielfältigung dieser Unterlage,
Verwertung und Mitteilung ihres Inhalts nicht
gestattet, soweit nicht ausdrücklich zugestanden.
Zuwerhandlungen verpflichten zu Schadenersatz.

Bemerkung - Note max. Fraeser-Ø: 80mm	Technische Daten - technical data Weight = 3.782 [kg] Torque max. (M1/M2) = 20 / 60 [Nm] Speed max. (n1/n2) = 6000 / 2000 [1/min] Gear ratio (i)=n1:n2 = 3:1	Benennung - Title Scheibenfräserkopf Radial saw milling head	 EWS Weigle GmbH & Co. KG Maybachstr. 1 D-73066 Uhlingen www.ews-tools.de Technische Änderungen vorbehalten! Subject to technical modifications! IDENT: D-EWS-000406 Nr. - No. 64.3027180913	 MNR REV: -/B 118621	
---	--	--	---	---	---