

Capto C5-Aufnahme  
Capto C5-Adaptor

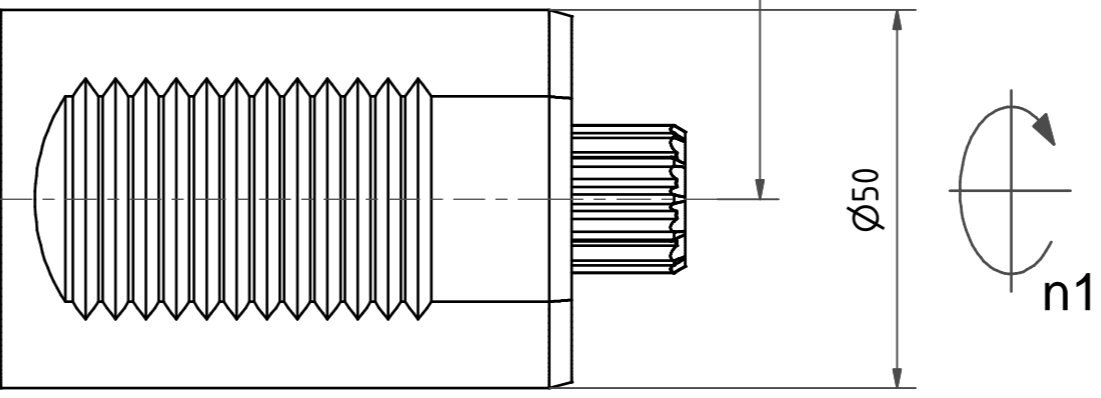

Clamping torque: 70Nm

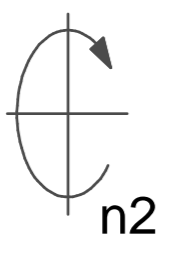
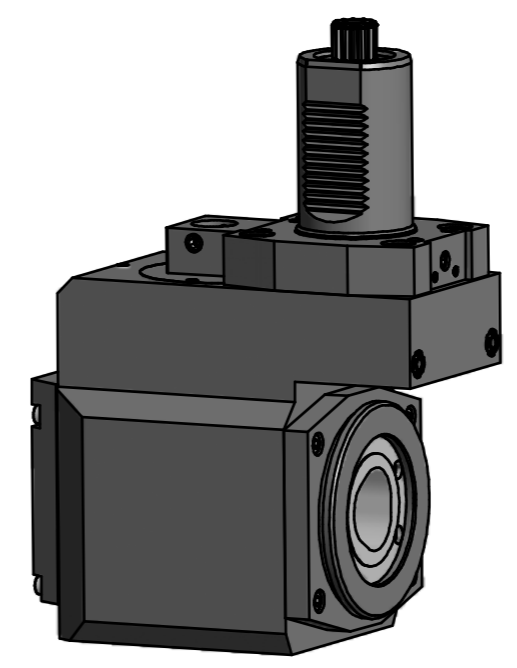
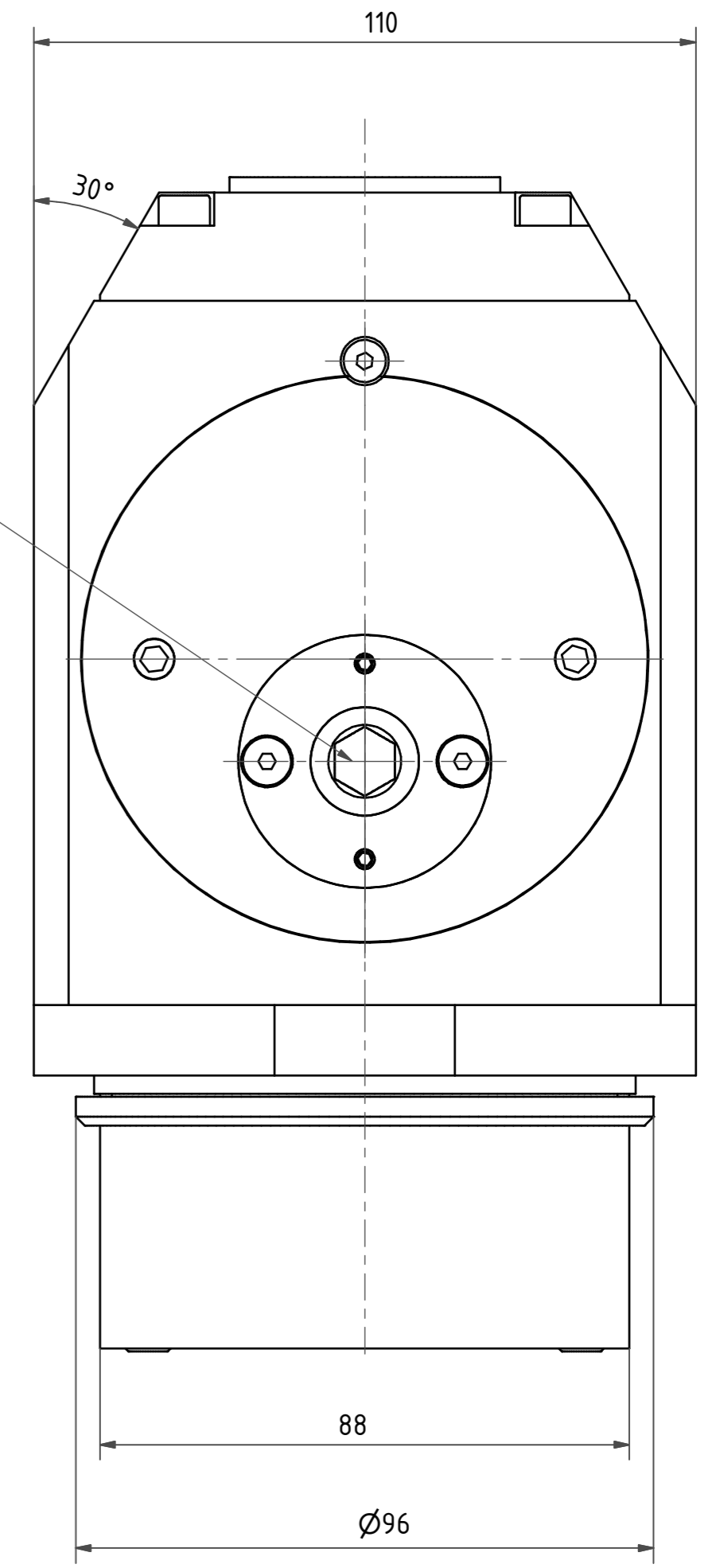

Copyright **EWS Tool Technologies**  
Weitergabe und Vervielfältigung dieser Unterlage,  
Verwertung und Mitteilung ihres Inhalts nicht  
gestattet, soweit nicht ausdrücklich zugestanden.  
Zuwendungen verpflichten zu Schadenersatz.

Benennung - Note	Technische Daten - Technical data		Benennung - Title	Technische Änderungen vorbehalten! Subject to technical modifications! Nr. <b>80.50C55482R</b> File: 80.50C55482_OUT.idw	 DIN A2
	M <sub>1</sub> / M <sub>2</sub> = 100 / 100 Nm n <sub>1</sub> / n <sub>2</sub> = 4000 / 4000 1/min i (N1:N2) = 1:1	<b>Radial Bohr und Fräskopf. zurückges</b> <b>Radial drill. and mill. head offset</b>			
drawing name date Krafschmann 11.08.2006		EWS Weigete GmbH & Co. KG Maybachstr. 1 D-73066 Ulm/lingen Tel. +49(0)7161/93040-10			