

W-Verzahnung Lizenz Index-Werke  
W-tooth system licence Index-Corporation

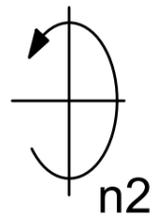

Spannzange / collet ER20 DIN6499  
Spannbereich / clamping range: 1,0 - 13,0

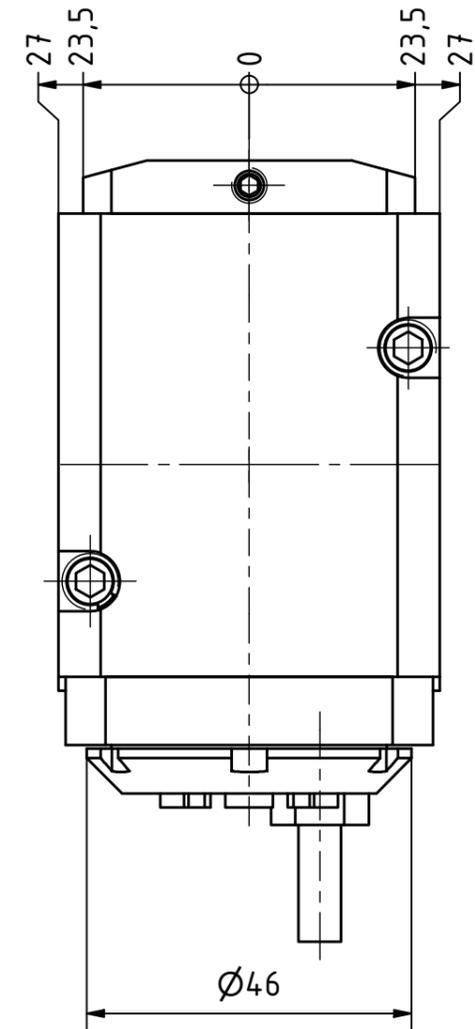
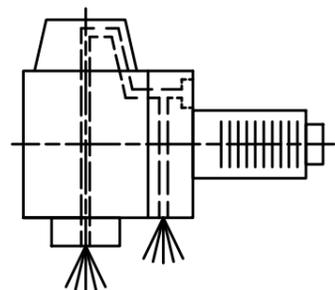

Innen- und Aussenkuehlung / Inside and outside coolant supply  
Kuehlmittelfiltrierung <math>< 50\mu</math> / coolant filtration <math>< 50\mu</math>

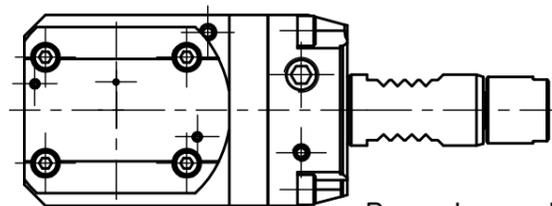

Doppelverzahnung Lizenz Traub  
double tooth system licence Traub

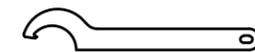
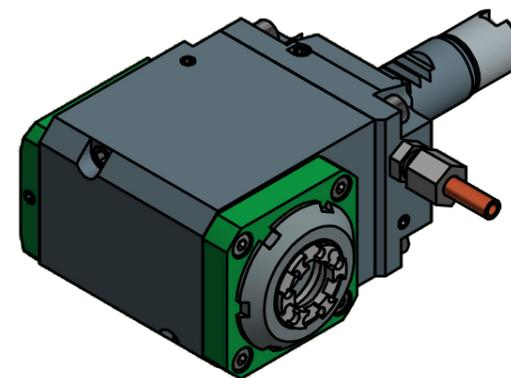

Hakenschlüssel  
mit Nase  
Hook wrench with  
nose end  
DIN1810 A 45x50

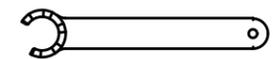

Spannzangenschlüssel für  
innenliegende Mutter  
Clamping wrench for  
internal collet  
220AX

Copyright **EWS Tool Technologies**  
Weitergabe und Vervielfaeltigung dieser Unterlage,  
Verwertung und Mitteilung ihres Inhalts nicht  
gestattet, soweit nicht ausdrecklich zugestanden.  
Zuwiderhandlungen verpflichten zu Schadenersatz.

Bemerkung - Note  
Für Trockenlauf geeignet!  
Use without coolant fluid allowed!

Technische Daten - technical data  
Weight = 2.398 [kg]  
Torque max. (M1/M2) = 11 / 11 [Nm]  
Speed max. (n1/n2) = 8000 / 8000 [1/min]  
Gear ratio (i)=n1:n2 = 1:1  
Pressure (pmax) = 70 [bar]

Benennung - Title  
**Radial Bohr und Fräskopf**  
**Radial drilling and milling head**



Nr. - No.  
**60.2020C100RLIKDWIM**

Technische Aenderungen vorbehalten!  
Subject to technical modifications!  
IDENT: DEWS007485



REV: -/A

MNR.  
**150369**

