

Spannzange / collet ER32 DIN6499
 Spannbereich / clamping range: 2,0 - 20,0

Gewindebohrzange / tapping collet
 ET-1-32 M5-M12

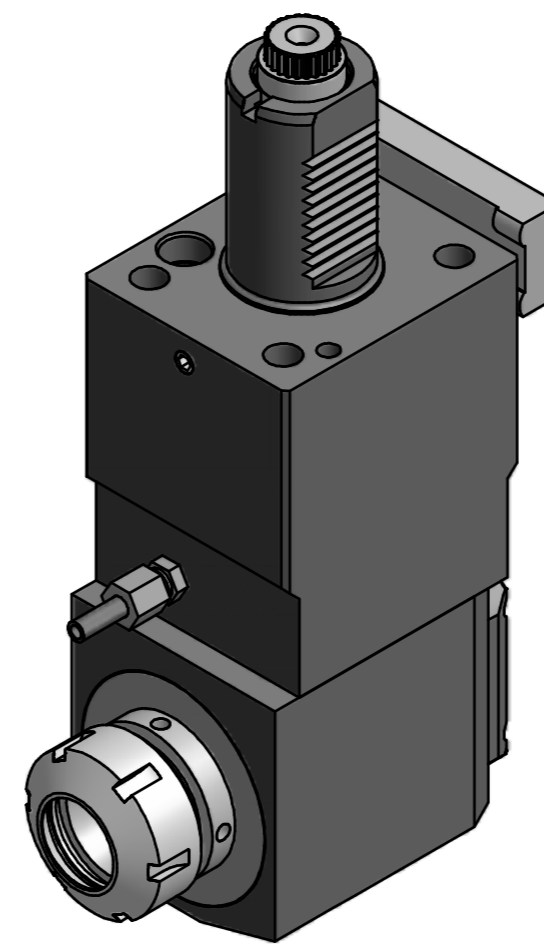
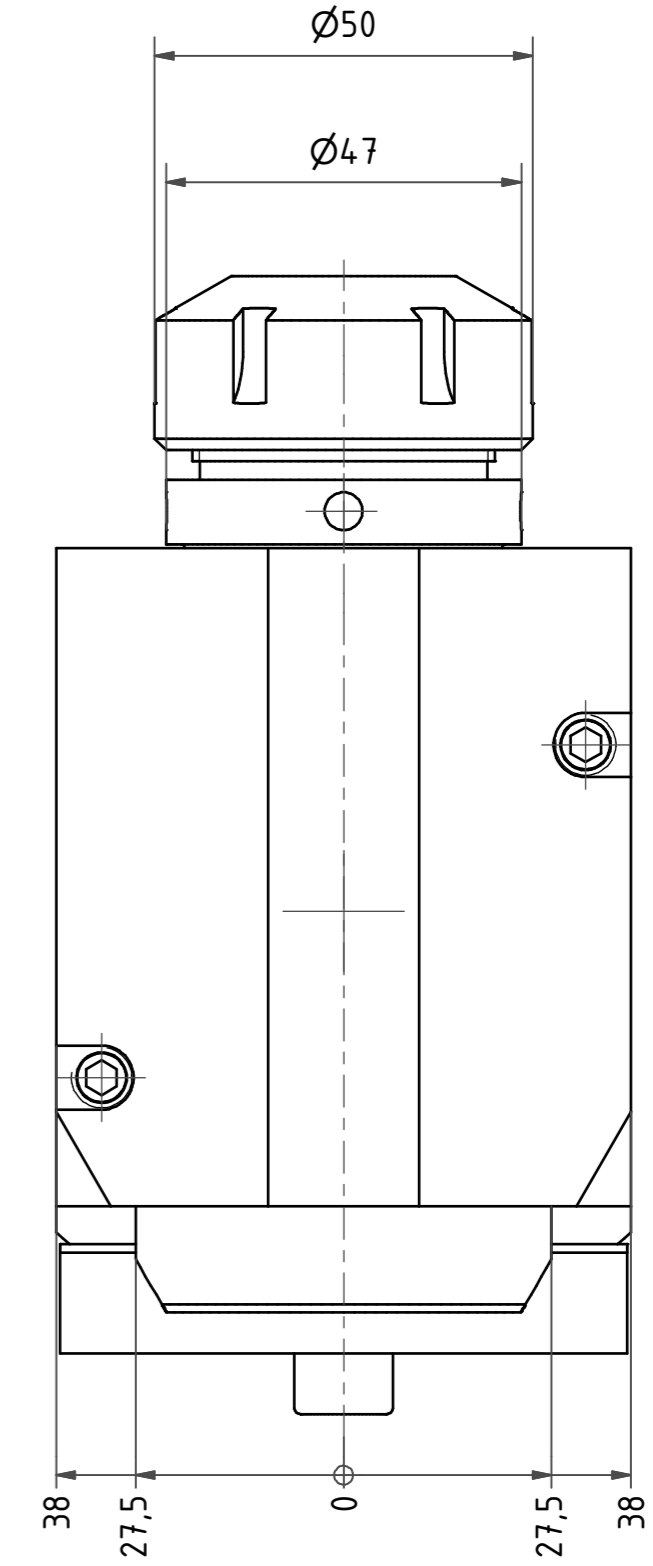
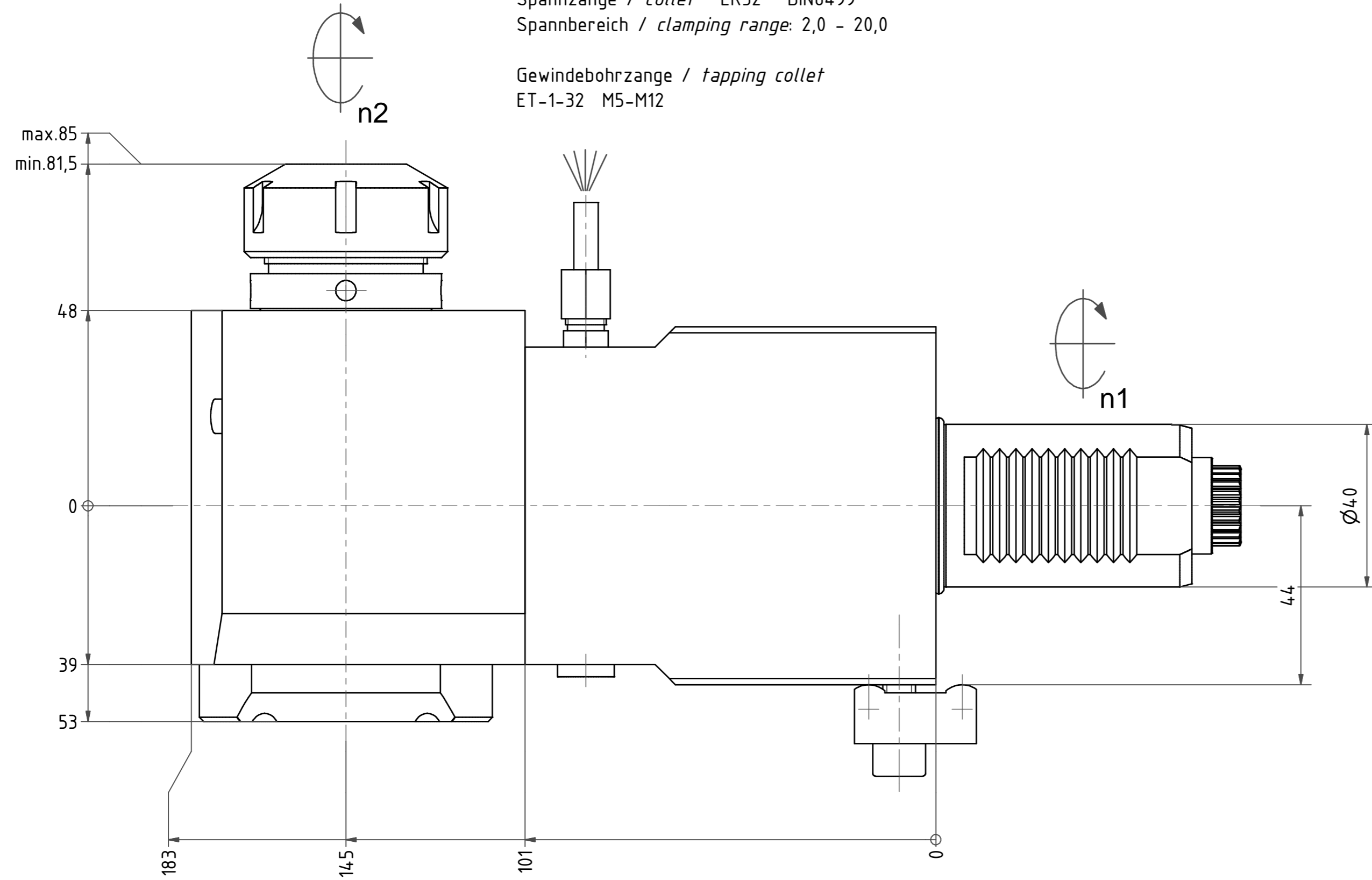

 Hakenschlüssel
 mit Zapfen
 Hook wrench
 with fixed pin
 DIN1810 B 45x50

 Spannzangenschlüssel
 Clamping wrench
 232

Copyright **EWS Tool Technologies**
 Weitergabe und Vervielfältigung dieser Unterlage,
 Verwertung und Mitteilung ihres Inhalts nicht
 gestattet, soweit nicht ausdrücklich zugestanden.
 Zuwiderhandlungen verpflichten zu Schadenersatz.

Bemerkung - Note	Technische Daten - Technical data		Benennung - Title	name	date	Technische Änderungen vorbehalten! Subject to technical modifications!
	M ₁ / M ₂ = 50 / 50 Nm	M ₁ / M ₂ = 50 / 50 Nm				
	n ₁ / n ₂ = 6000 / 6000 1/min	Radial Bohr und Fräskopf Radial drilling and milling head	EWS	Weigete GmbH & Co. KG Maybachstr. 1 D-73066 Ulm/lingen Tel. +49(0)7161/93040-10	Nr. 60.4032DOS310LGL	
	i (N ₁ :N ₂) = 1:1					DIN A2
						File: D-EWS-071942.idw