

Spannzange / collet ER50 DIN6499  
 Spannbereich / clamping range: 6,0 - 34,0

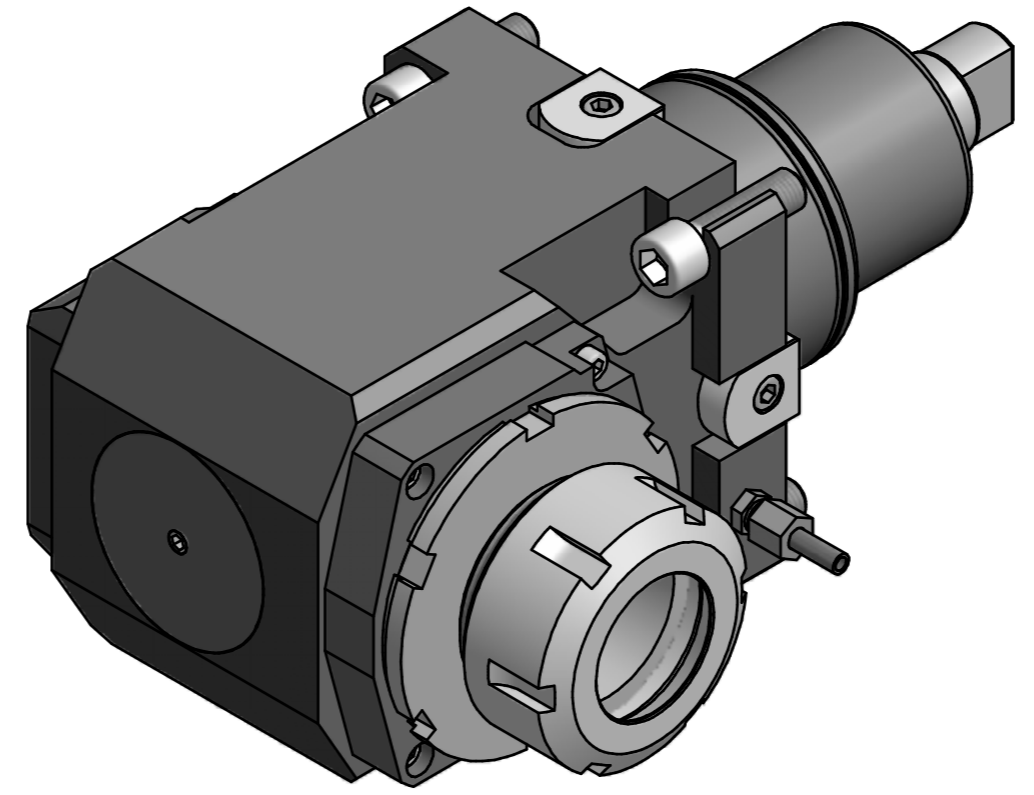
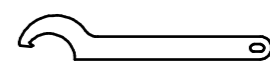
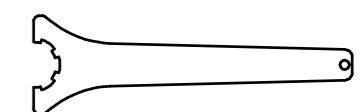

-  Hakenschlüssel mit Nase  
Hook wrench with nose end  
DIN1810 A 110x115
-  Spannzangenschlüssel  
Clamping wrench  
250

Copyright **EWS Tool Technologies**  
 Weitergabe und Vervielfältigung dieser Unterlage,  
 Verwertung und Mitteilung ihres Inhalts nicht  
 gestattet, soweit nicht ausdrücklich zugestanden.  
 Zuwiderhandlungen verpflichten zu Schadenersatz.

Bemerkung - Note mit Kegelrollenlager with taper roller bearing(s)	Technische Daten - technical data M <sub>1</sub> / M <sub>2</sub> = 80 / 160 Nm n <sub>1</sub> / n <sub>2</sub> = 4 000 / 2000 1/min i (N <sub>1</sub> :N <sub>2</sub> ) = 2:1	Benennung - Title <b>Radial Bohr und Fräskopf</b> <i>Radial drilling and milling head</i>	<table border="1" style="width: 100%; border-collapse: collapse;"> <tr> <td style="font-size: 8px;">drawing</td> <td style="font-size: 8px;">name</td> <td style="font-size: 8px;">date</td> <td rowspan="2" style="font-size: 8px;">Technische Änderungen vorbehalten! Subject to technical modifications!</td> </tr> <tr> <td style="font-size: 8px;">Lukjanow</td> <td style="font-size: 8px;">29.04.2013</td> <td style="font-size: 8px;">Nr.</td> </tr> <tr> <td colspan="3" style="text-align: center;"><b>EWS</b> <small>EWS Werkzeug GmbH &amp; Co. KG Maybachstr. 1 D-73066 Ulm/ingen Tel. +49(0)7161/93040-100</small></td> <td style="font-size: 8px;"><b>60.8550KR1809I2GLX110</b></td> </tr> <tr> <td colspan="3" style="font-size: 8px;">MNR: 151488</td> <td style="font-size: 8px;">IDENT: D-EWS-135682 - Blatt - page 1 (1)</td> </tr> </table>	drawing	name	date	Technische Änderungen vorbehalten! Subject to technical modifications!	Lukjanow	29.04.2013	Nr.	<b>EWS</b> <small>EWS Werkzeug GmbH &amp; Co. KG Maybachstr. 1 D-73066 Ulm/ingen Tel. +49(0)7161/93040-100</small>			<b>60.8550KR1809I2GLX110</b>	MNR: 151488			IDENT: D-EWS-135682 - Blatt - page 1 (1)
drawing	name	date	Technische Änderungen vorbehalten! Subject to technical modifications!															
Lukjanow	29.04.2013	Nr.																
<b>EWS</b> <small>EWS Werkzeug GmbH &amp; Co. KG Maybachstr. 1 D-73066 Ulm/ingen Tel. +49(0)7161/93040-100</small>			<b>60.8550KR1809I2GLX110</b>															
MNR: 151488			IDENT: D-EWS-135682 - Blatt - page 1 (1)															