

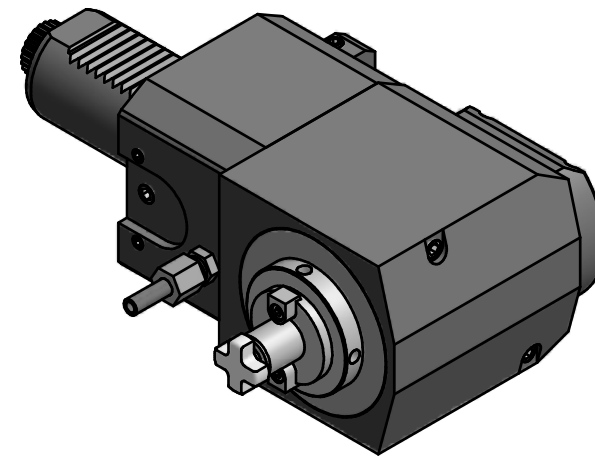
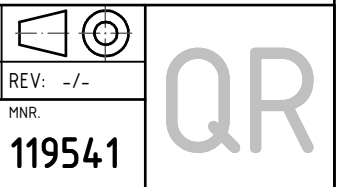

  
 Hakenschlüssel  
 mit Zapfen  
 Hook wrench  
 with fixed pin  
 DIN1810 B 45x50



Copyright **EWS Tool Technologies**  
 Weitergabe und Vervielfaeltigung dieser Unterlage,  
 Verwertung und Mitteilung ihres Inhalts nicht  
 gestattet, soweit nicht ausdruuecklich zugestanden.  
 Zuwiderhandlungen verpflichten zu Schadenersatz.

Bemerkung - Note	Technische Daten - technical data Weight = 6.545 [kg] Torque max. (M1/M2) = 50 / 50 [Nm] Speed max. (n1/n2) = 6000 / 6000 [1/min] Gear ratio (i)=n1:n2 = 1.1	Benennung - Title <b>Radial Fräskopf</b> <b>Radial milling head</b>	 EWS Weigele GmbH & Co. KG Maybachstr. 1 D-73066 Uhingen www.ews-tools.de Nr. - No. <b>62.4016CTXL</b>	Technische Aenderungen vorbehalten! Subject to technical modifications! IDENT: D-EWS-201298 MNR. <b>119541</b>	
------------------	--	---	--	--	---