

Spannzange / collet ER32 DIN6499
Spannbereich / clamping range: 2,0 - 20,0

Doppelverzahnung Lizenz Traub
double tooth system licence Traub

 Hakenschlüssel
mit Nase
Hook wrench with
nose end
DIN1810 A 4,5x50

 Spannzangenschlüssel
Clamping wrench
232

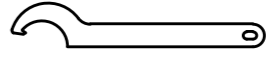
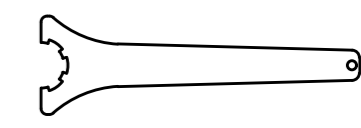
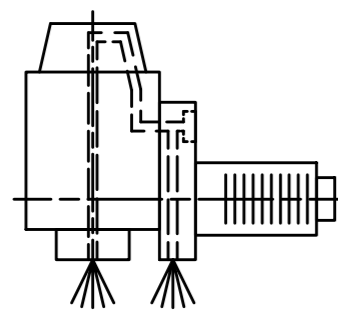

Innen- und Aussenkuehlung / Inside and outside coolant supply
Kuehlmittelfiltrierung-50µ / coolant filtration-50µ

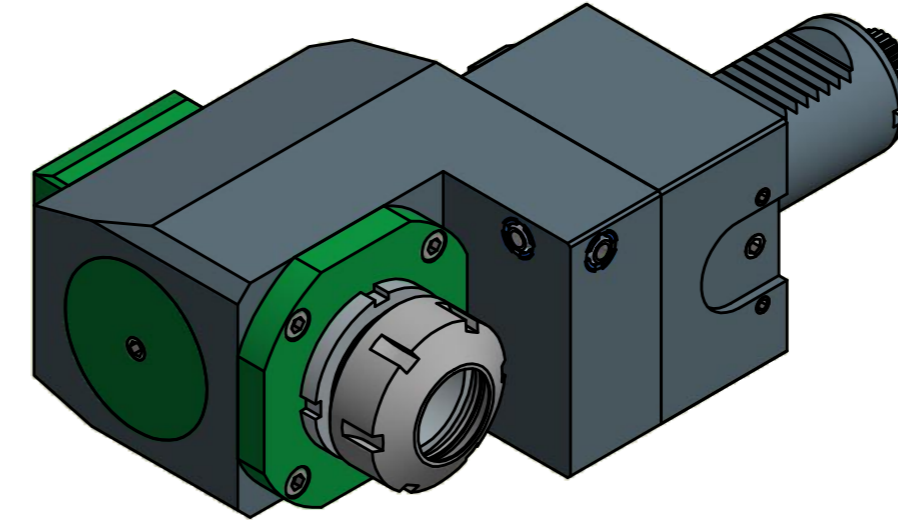
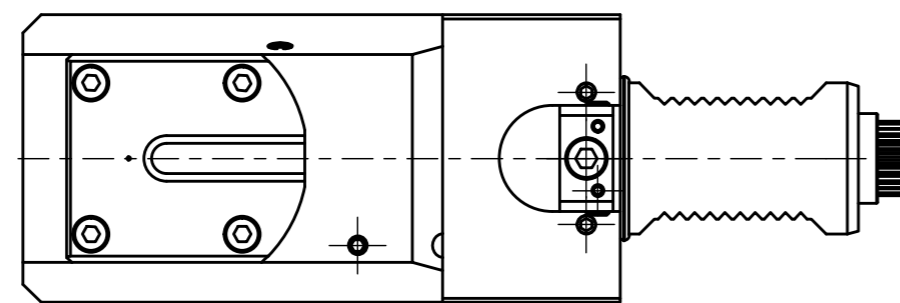

Copyright **EWS Tool Technologies**
Weitergabe und Vervielfaeltigung dieser Unterlage,
Verwertung und Mitteilung ihres Inhalts nicht
gestattet, soweit nicht ausdrecklich zugestanden.
Zuwaerhandlungen verpflichten zu Schadenersatz.

<p>Bemerkung - Note Für Trockenlauf geeignet! Use without coolant fluid allowed!</p>	<p>Technische Daten - technical data Weight = 7.598 [kg] Torque max. (M1/M2) = 50 / 50 [Nm] Speed max. (n1/n2) = 6000 / 6000 [1/min] Gear ratio (i)=n1:n2 = 1:1 Pressure (pmax) = 70 [bar]</p>	<p>Benennung - Title Radial Bohr und Fräskopf, zurückges Radial drill. and mill. head offset</p>	<p>EWS Tool Technologies EWS Weigle GmbH & Co. KG Maybachstr. 1 D-73066 Uhingen www.ews-tools.de</p>	<p>Technische Aenderungen vorbehalten! Subject to technical modifications! IDENT: D-EWS-061511</p>	<p>REV: -/- MNR. 1184.08</p>	<p>QR</p>
--	--	--	---	--	--------------------------------------	------------------