

Spannzange / collet ER32 DIN6499
Spannbereich / clamping range: 2,0 - 20,0

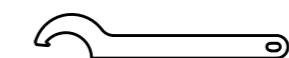

Hakenschlüssel
mit Nase
Hook wrench with
nose end
DIN1810 A 68x75

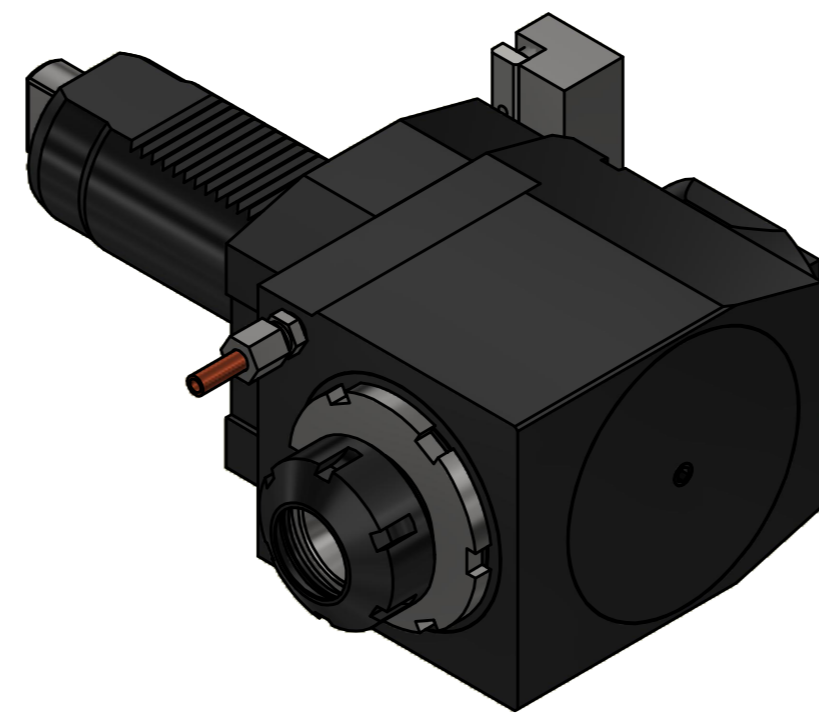
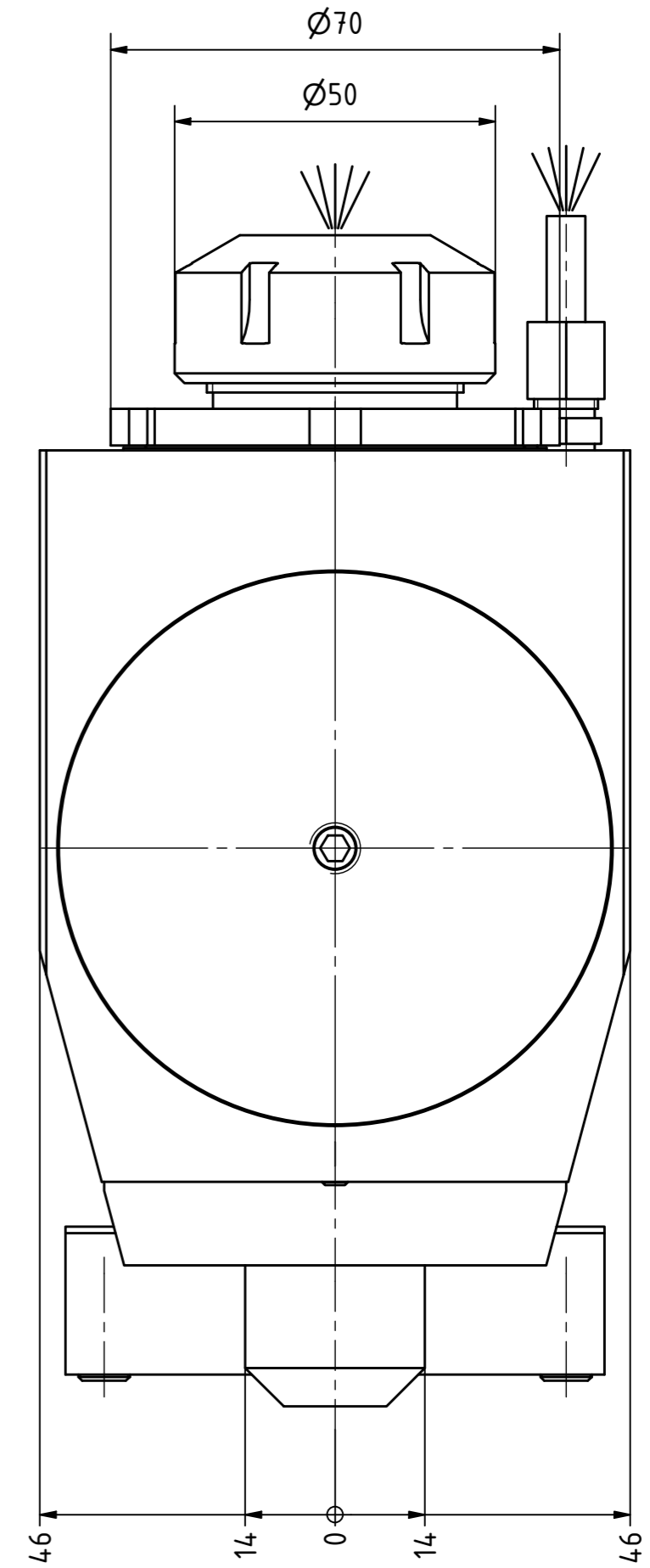
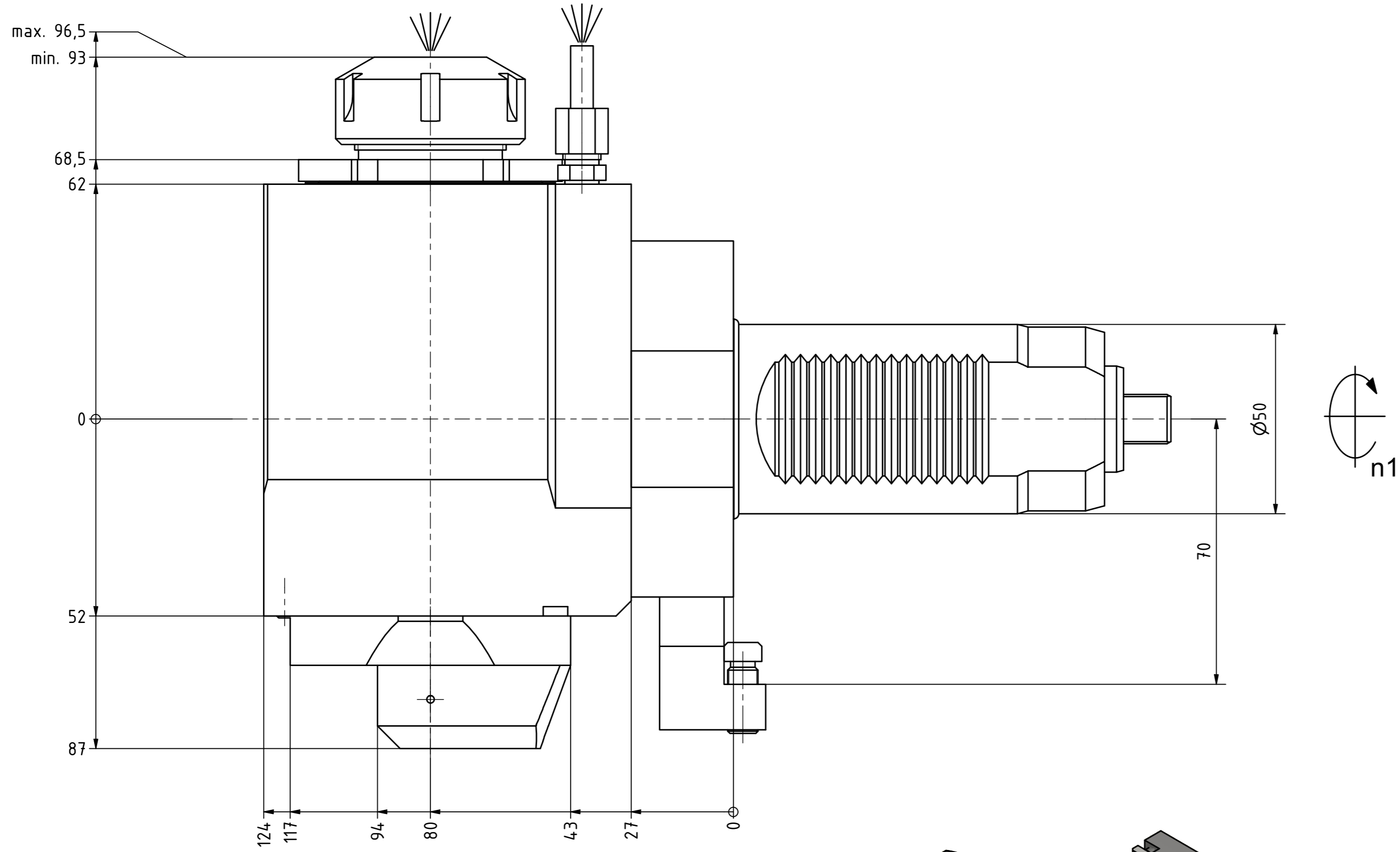
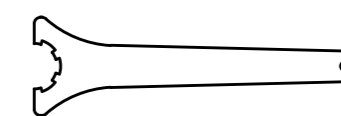

Spannzangenschlüssel
Clamping wrench
232

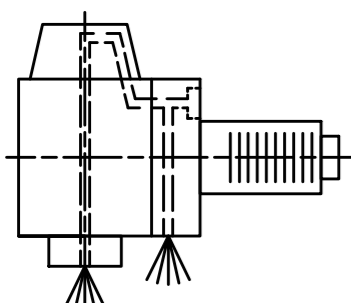

Innen- und Aussenkuehlung / Inside and outside coolant supply
Kein Trockenlauf / No dry run
Kuehlmittefiltrierung-50µ / coolant filtration-50µ

Bemerkung - Note

Nicht ohne Kuehlmitte betreiben!
Not for use without coolant-fluid!

Technische Daten - technical data

Weight = 9,436 [kg]
Torque max. (M1/M2) = 100 / 50 [Nm]
Speed max. (n1/n2) = 4000 / 8000 [1/min]
Gear ratio (i)=n1:n2 = 1:2
Pressure (pmax) = 70 [bar]

Benennung - Title

Radial Bohr und Fräskopf
Radial drilling and milling head

Copyright EWS Tool Technologies
Weitergabe und Vervielfaeltigung dieser Unterlage,
Verwertung und Mitteilung ihres Inhalts nicht
gestattet, soweit nicht ausdrecklich zugestanden.
Zuwiderhandlungen verpflichten zu Schadenersatz.



Nr. - No.
60.5032VL5LIK11

Technische Aenderungen vorbehalten!
Subject to technical modifications!
IDENT: DEWS14.7325

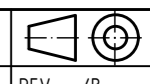

REV: -/B
MNR.
153893

