

Spannzange / collet ER32 DIN6499
Spannbereich / clamping range: 2,0 - 20,0

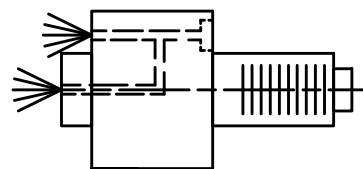

Innen- und Aussenkuehlung / Inside and outside coolant supply
Kein Trockenlauf / No dry run
Kuehlmittelfiltrierung 50μ / coolant filtration 50μ

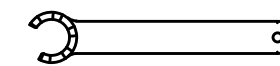
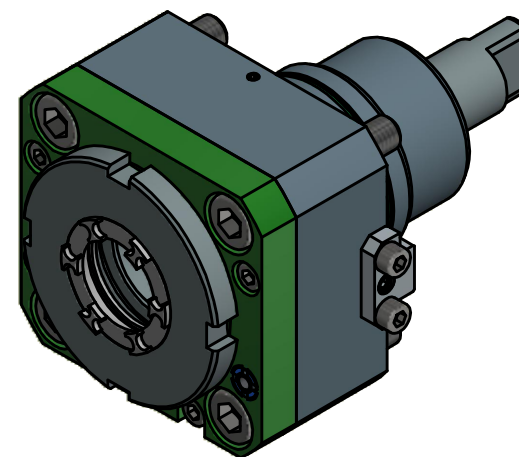

Spannzangenschlüssel für
innenliegende Mutter
Clamping wrench for
internal collet
232AX

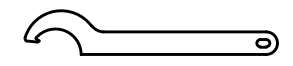

Hakenschlüssel
mit Nase
Hook wrench with
nose end
DIN1810 A 68x75

Copyright **EWS Tool Technologies**
Weitergabe und Vervielfaeltigung dieser Unterlage,
Verwertung und Mitteilung ihres Inhalts nicht
gestattet, soweit nicht ausdruücklich zugestanden.
Zuwiderhandlungen verpflichten zu Schadenersatz.

Bemerkung - Note
Nicht ohne Kuehlmittel betreiben!
Not for use without coolant-fluid!

Technische Daten - technical data	
Weight	= 3.057 [kg]
Torque max. (M1/M2)	= 50 / 50 [Nm]
Speed max. (n1/n2)	= 6000 / 6000 [1/min]
Gear ratio (i)=n1:n2	= 1:1
Pressure (pmax)	= 25 [bar]

Benennung - Title
Axial Bohr und Fräskopf
Axial drilling and milling head

EWS Tool Technologies
EWS Weigle GmbH & Co. KG
Maybachstr. 1
D-73066 Utingen
www.ews-tools.de

Nr. - No.
40.5532BIG1809IKIM

Technische Aenderungen vorbehalten!
Subject to technical modifications!
IDENT: DEWS016124
REV: -/A
MNR.
153842

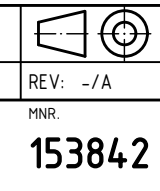

QR